



# Cincinnati, Ohio

**Ages 10+**

**287 pieces**

**#0001**

Create iconic Cincinnati landmarks with LEGO bricks!

This set is not affiliated or endorsed by the LEGO Group.



1

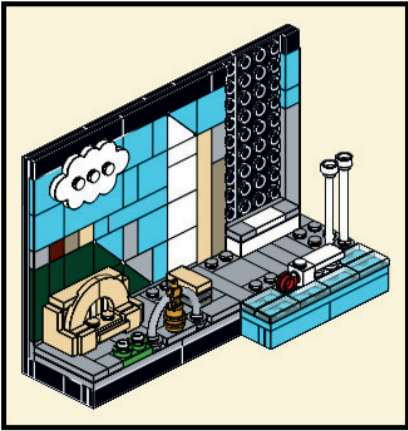
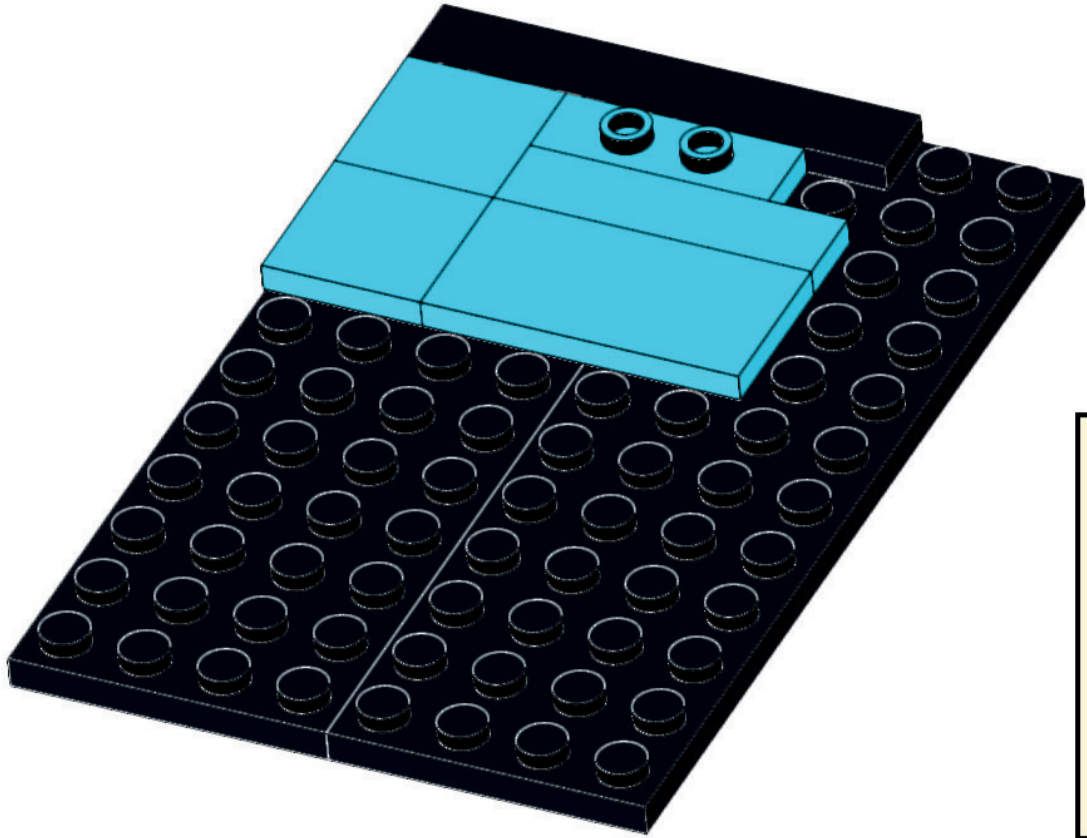
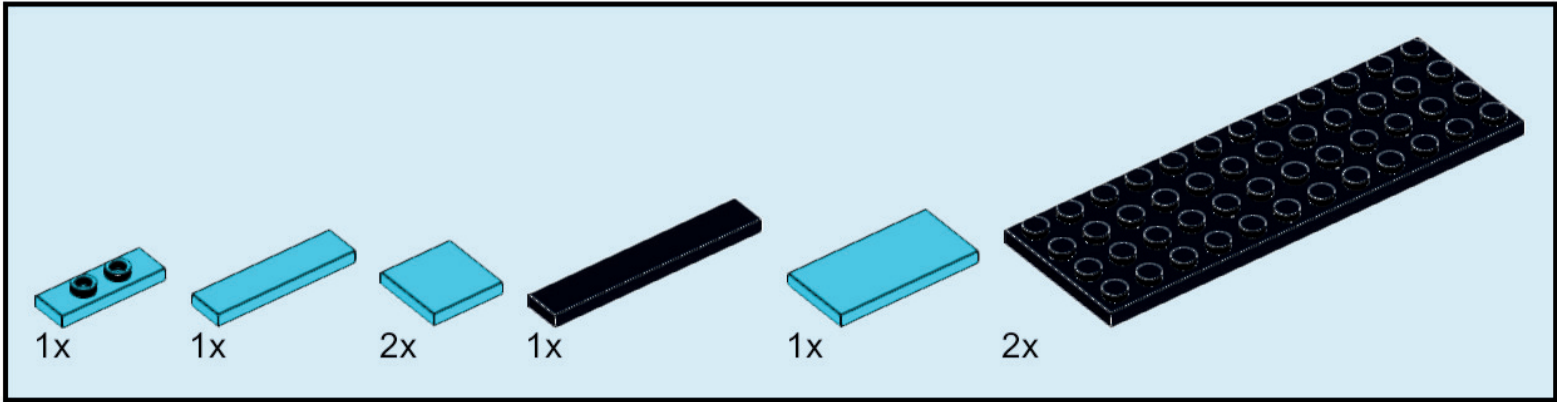

2

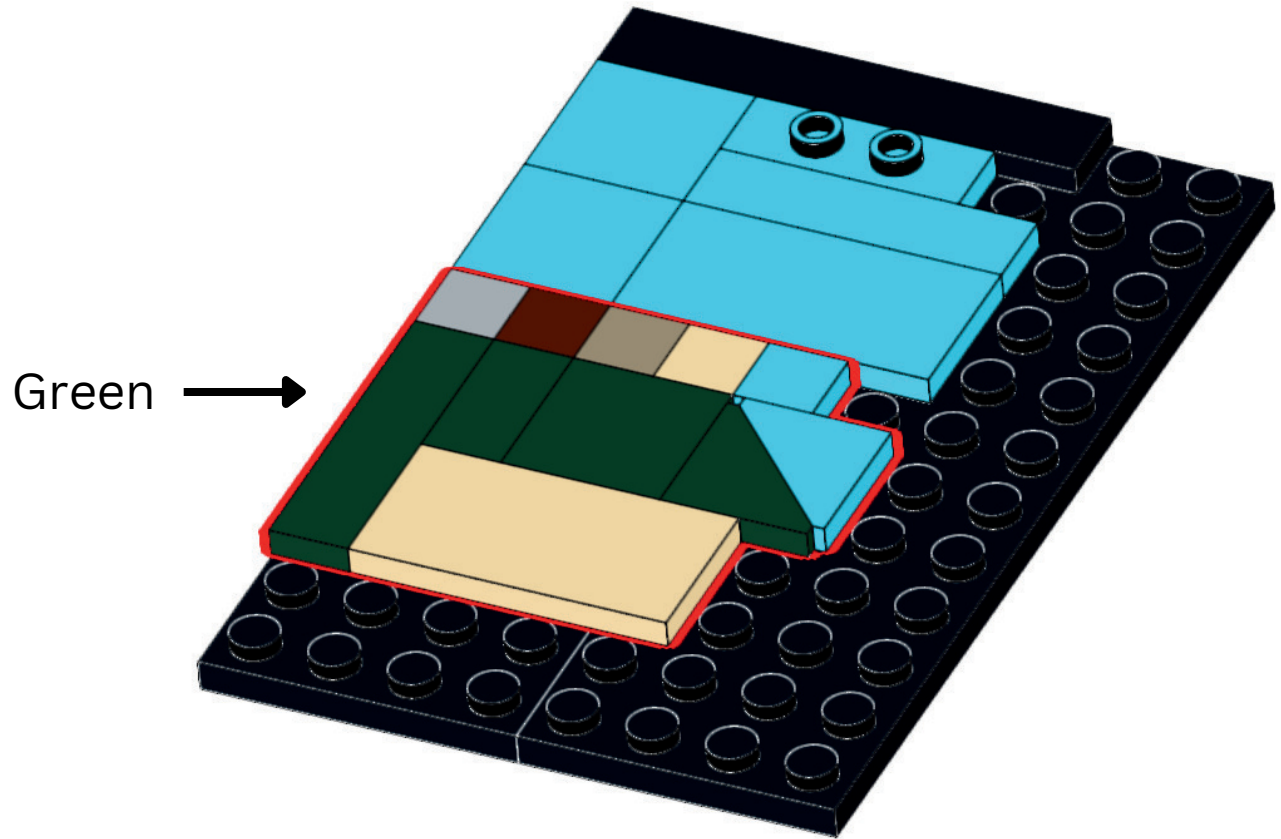
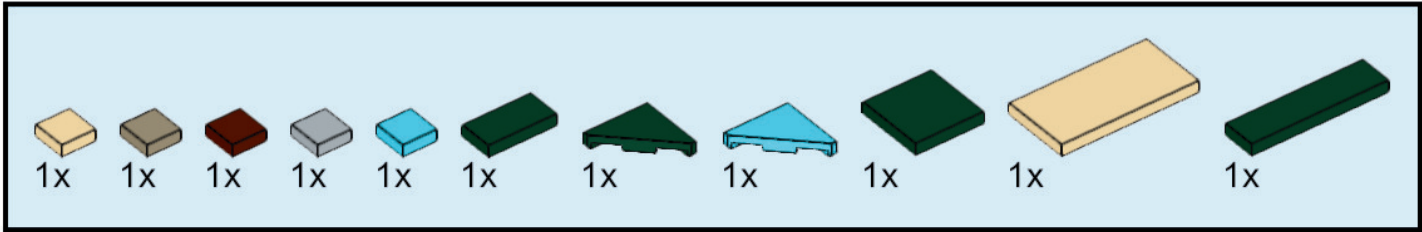

3

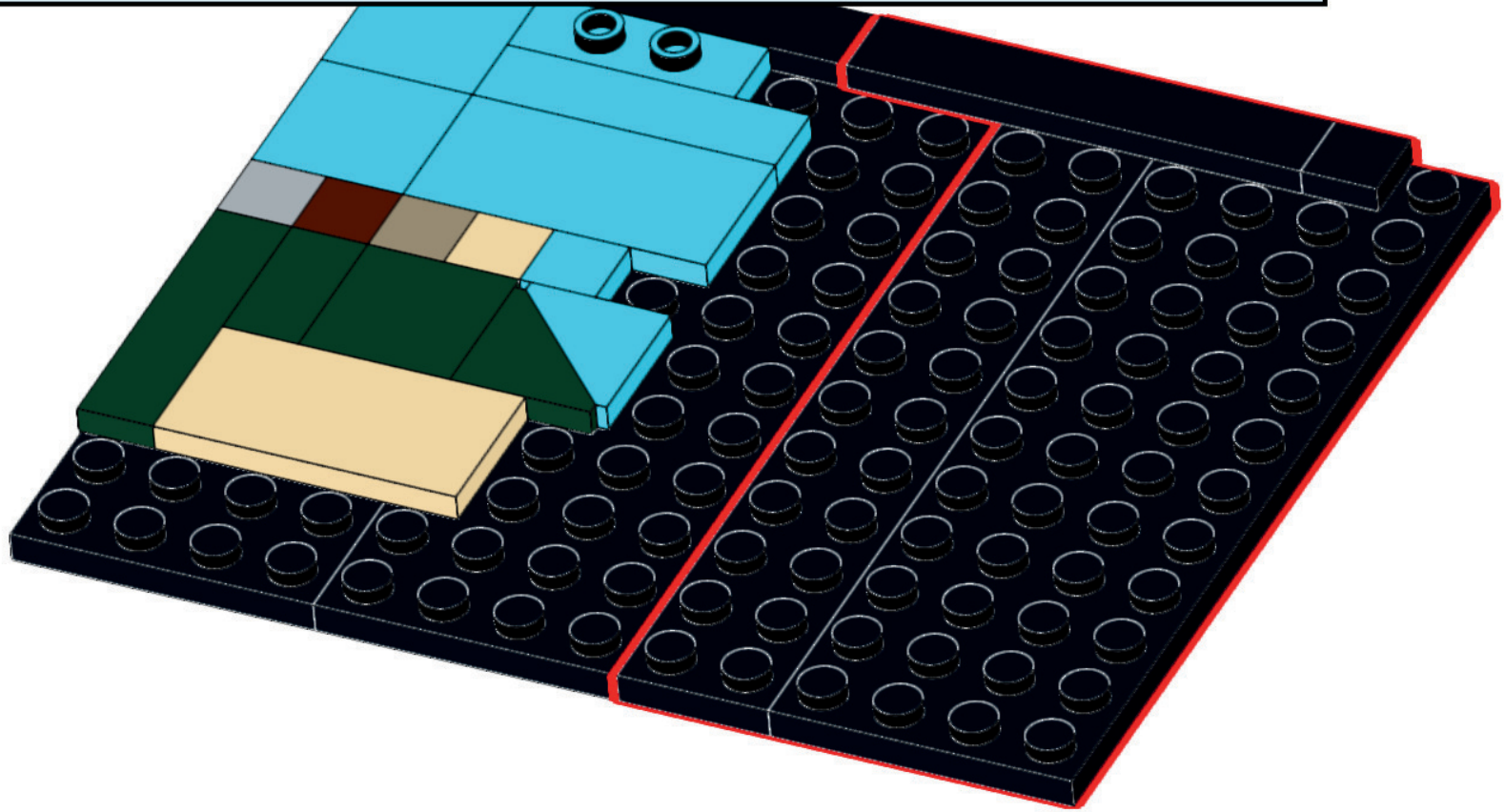
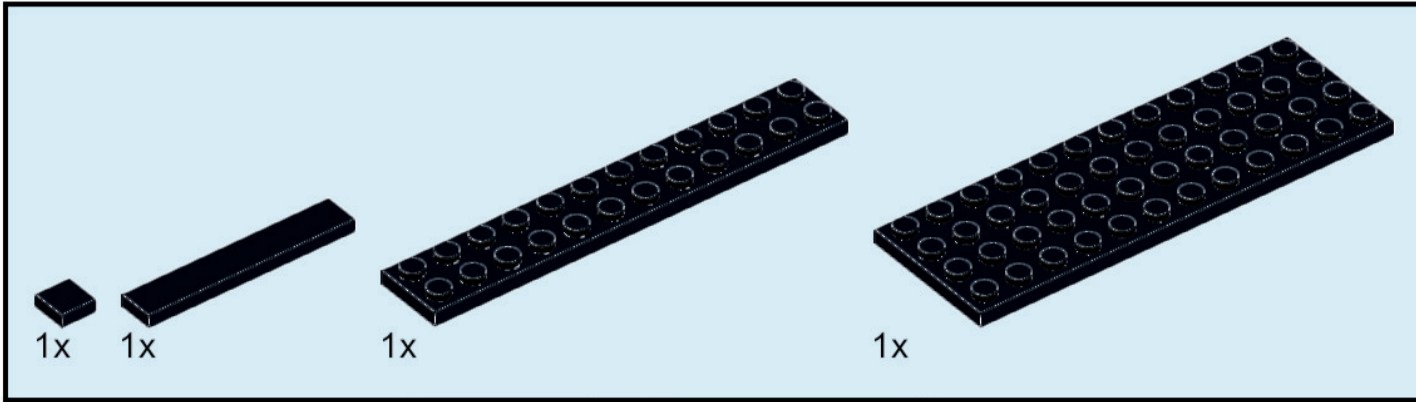

4

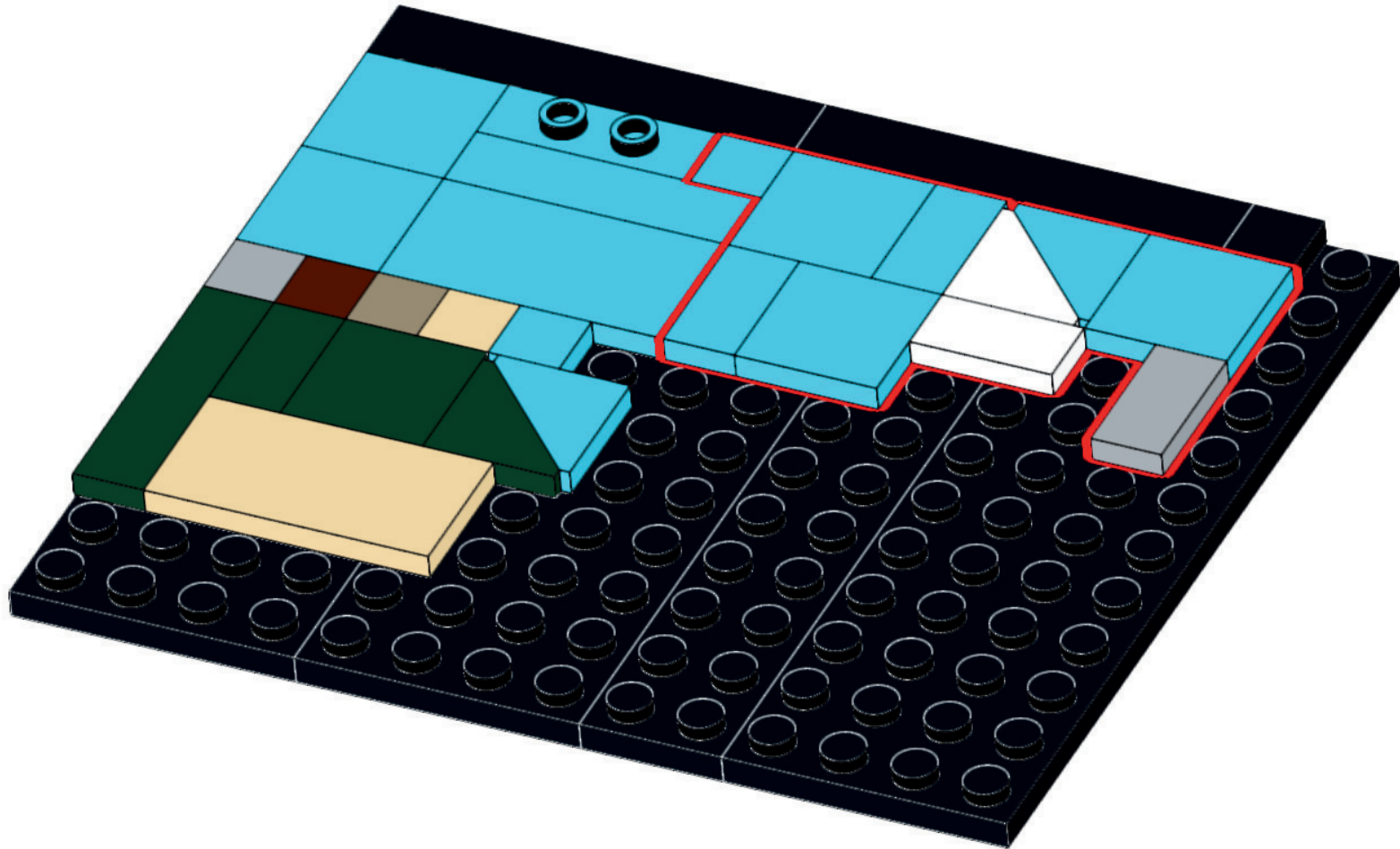
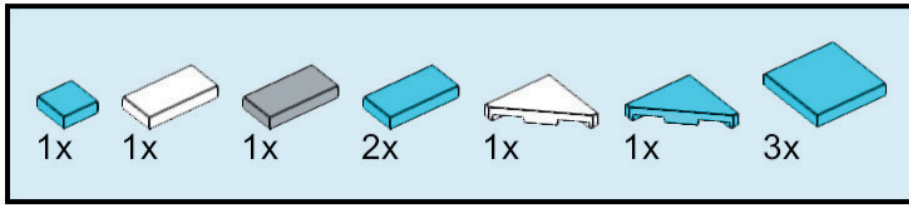

# 5

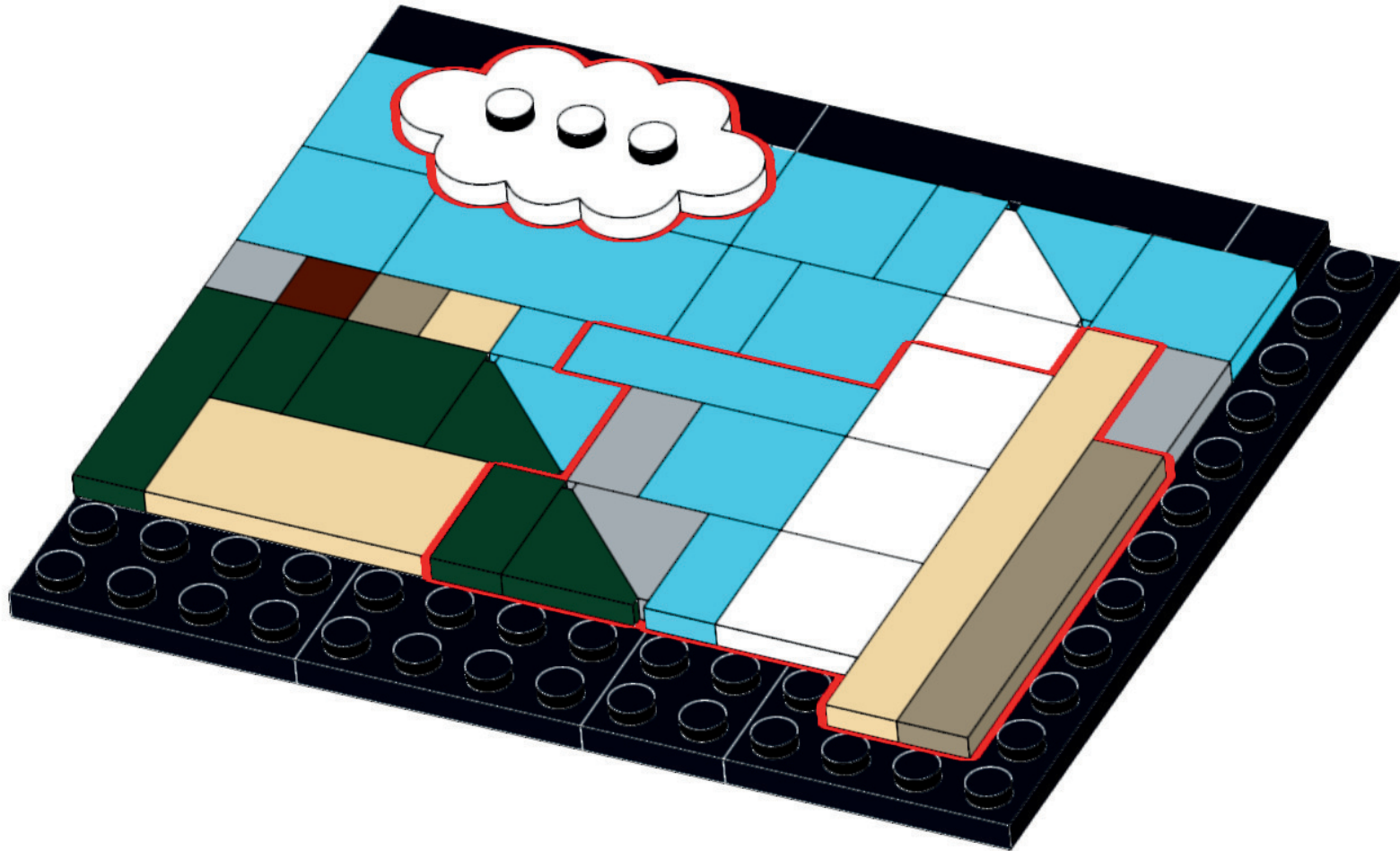
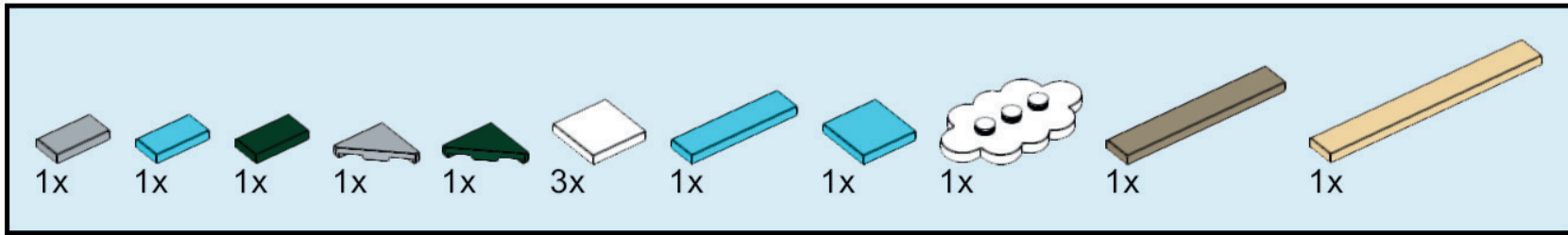

Cincinnati is known as the "The City of Seven Hills," a phrase dating back to the 1800s designed to connect the city to Rome, Italy.

6

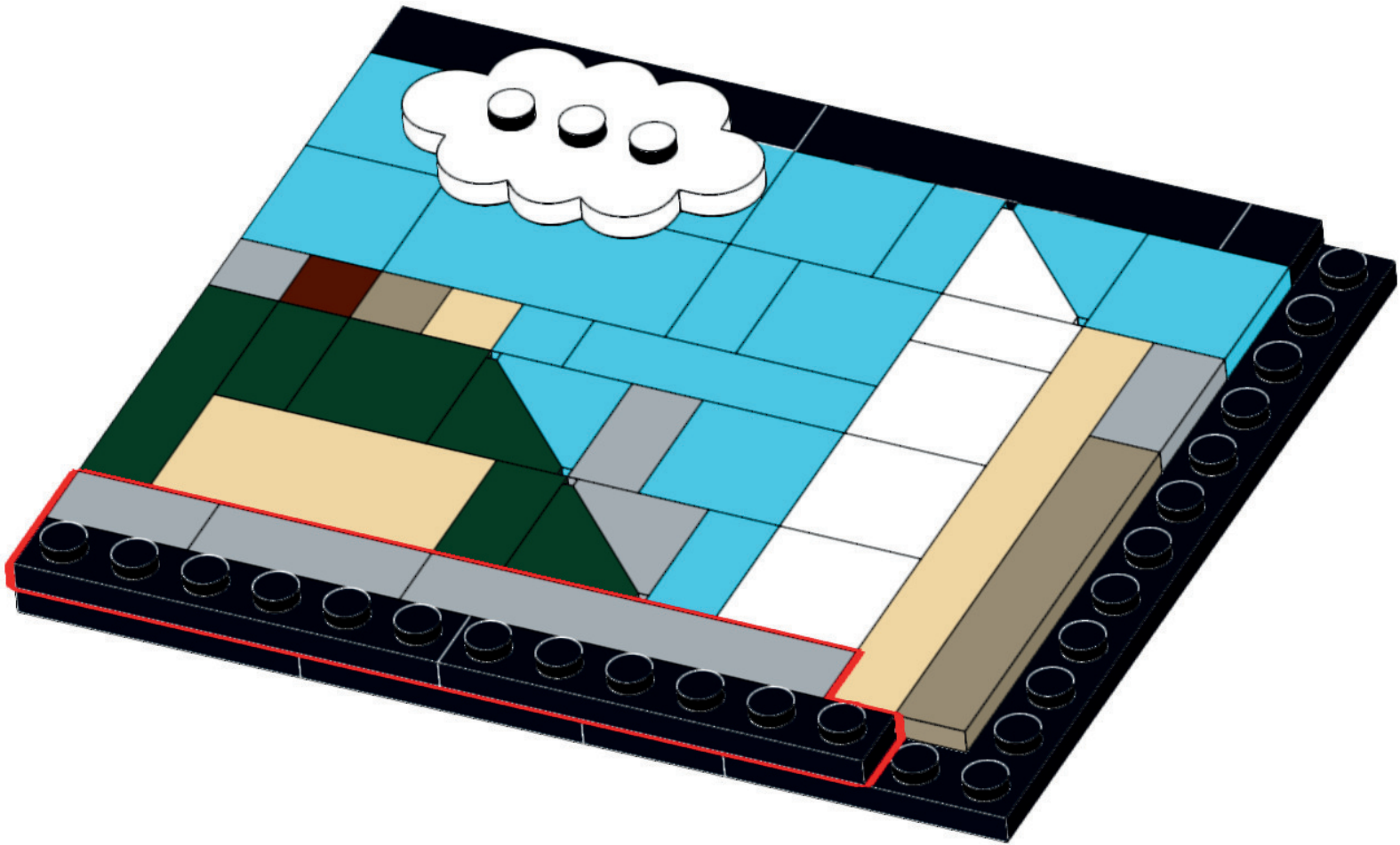
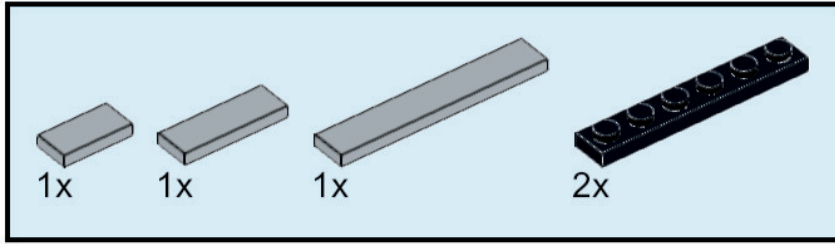

7

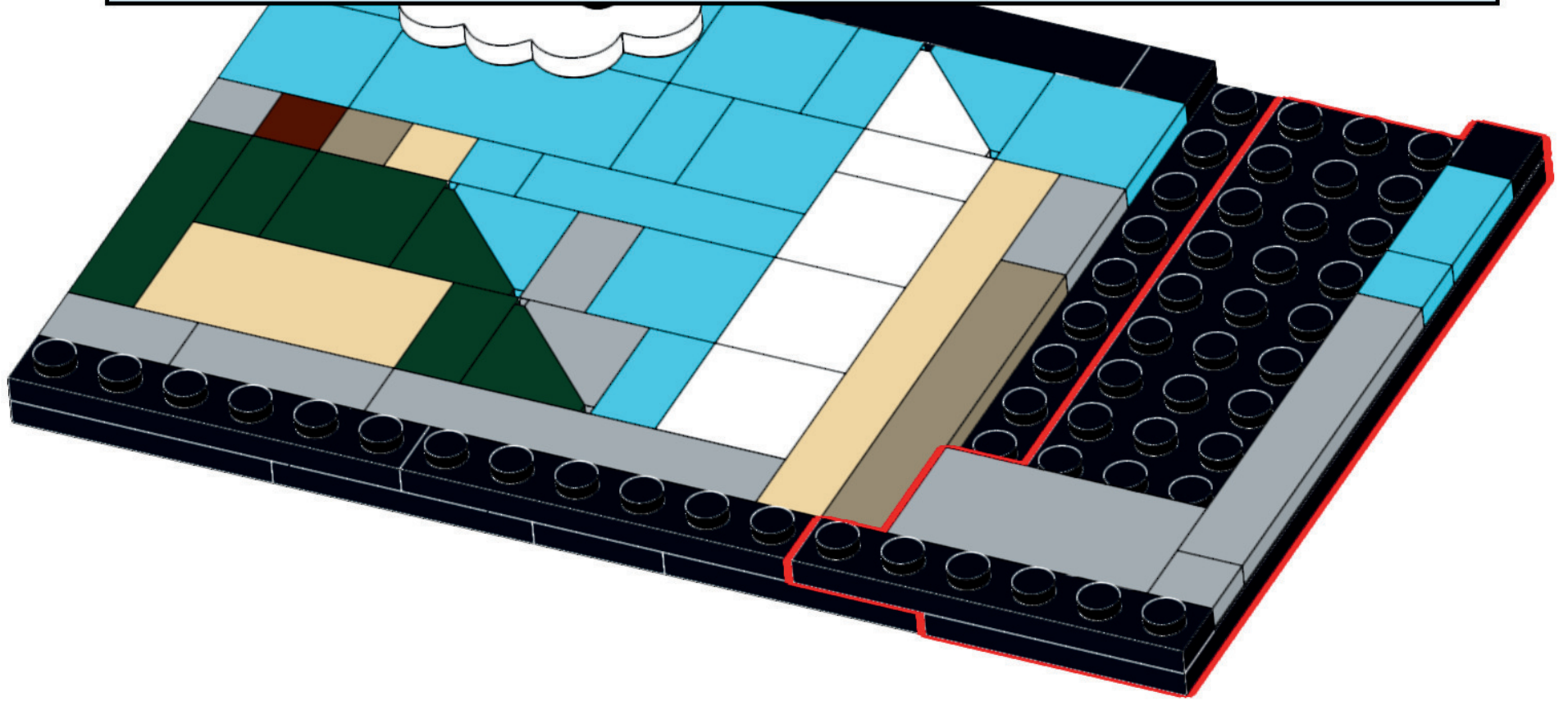
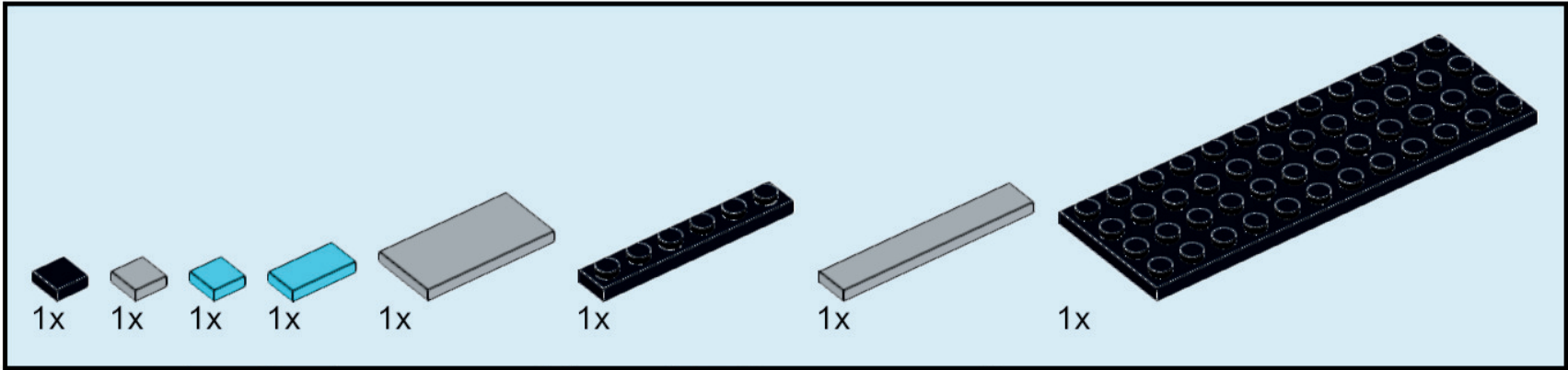

8

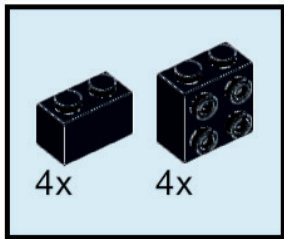
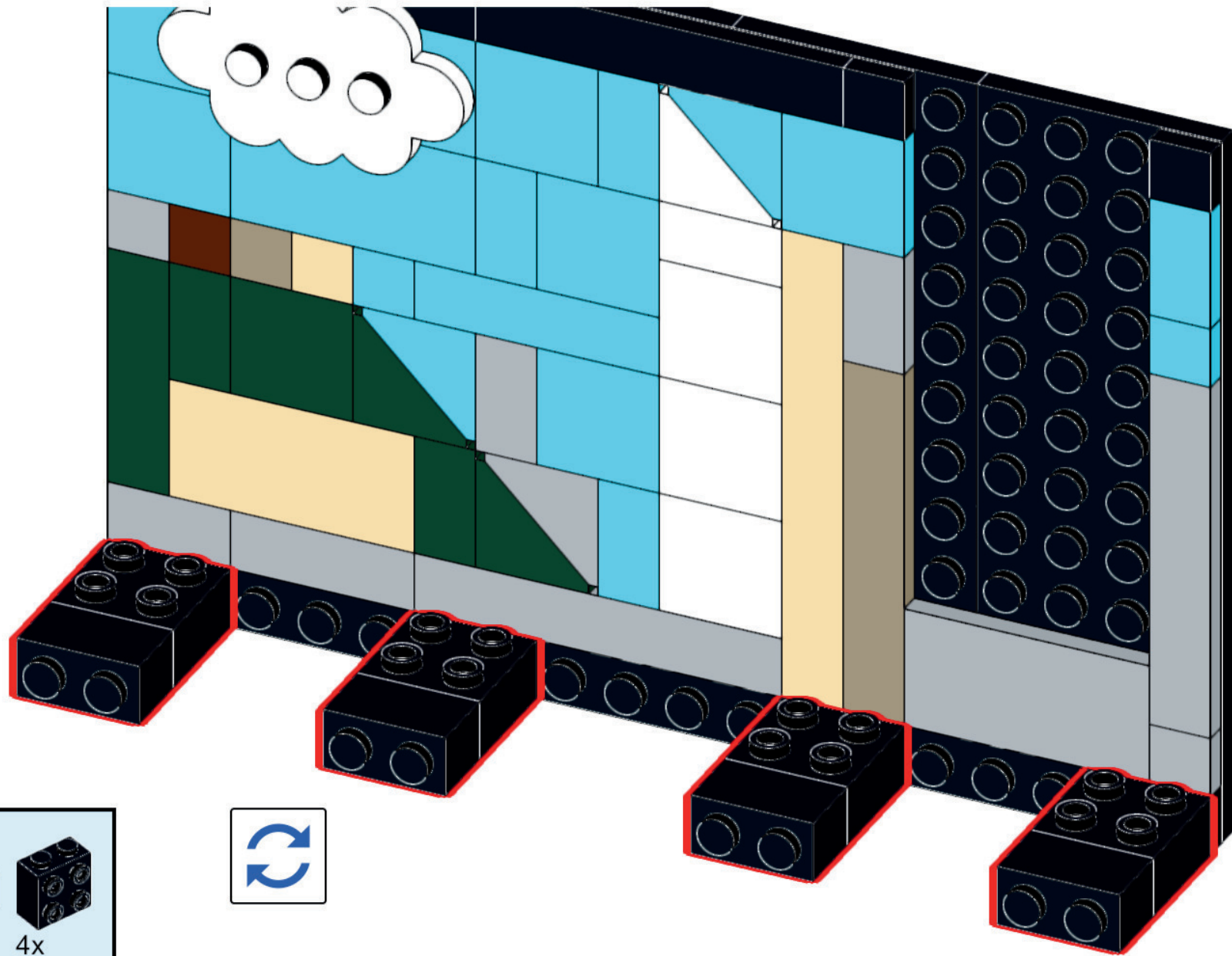

9

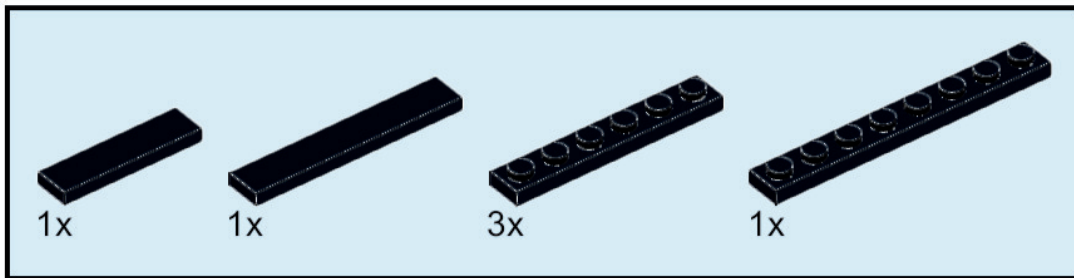
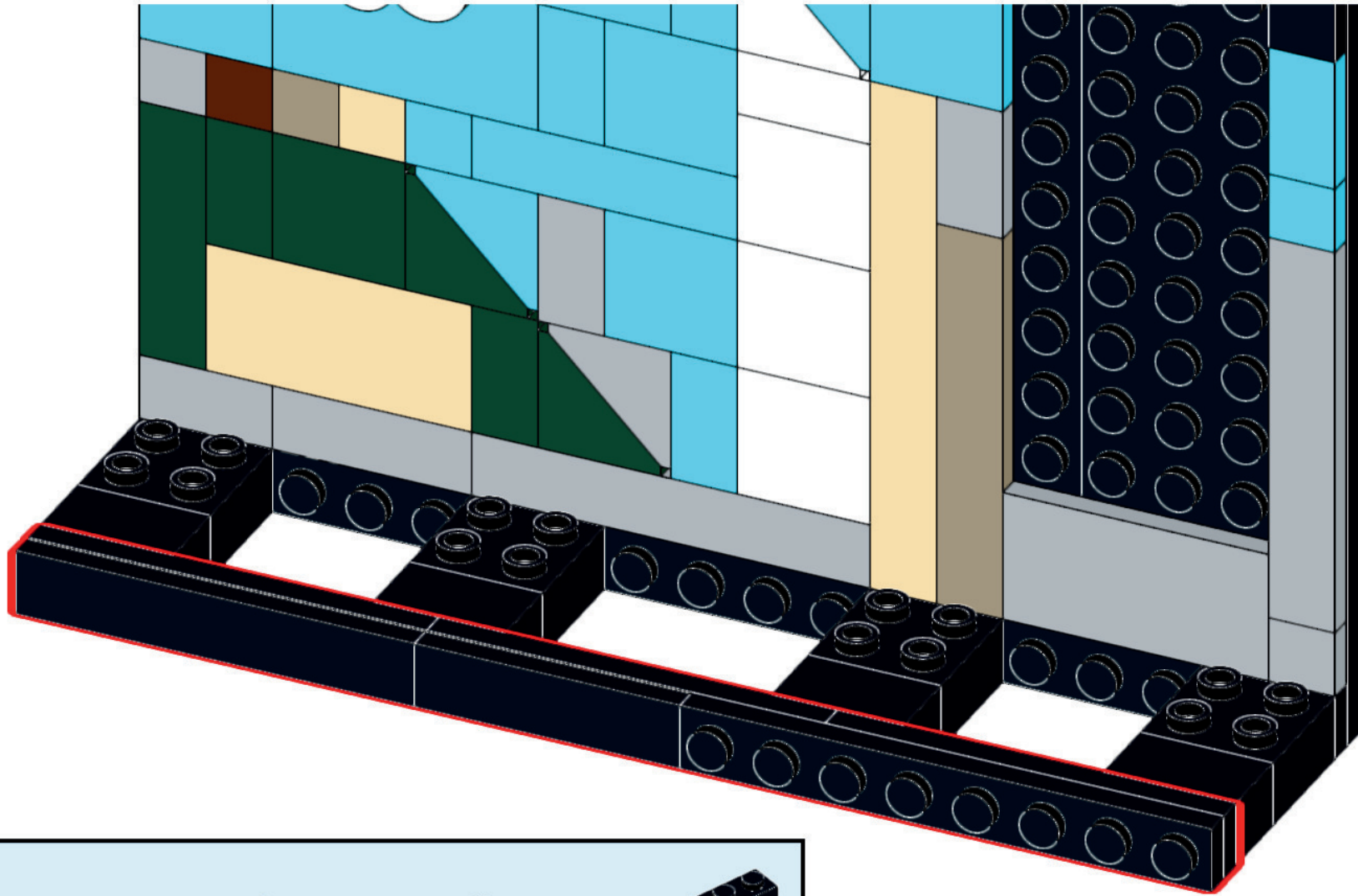

10

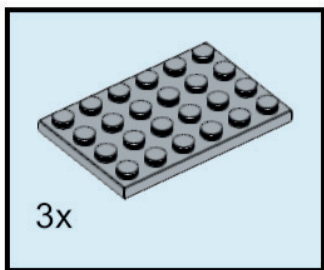
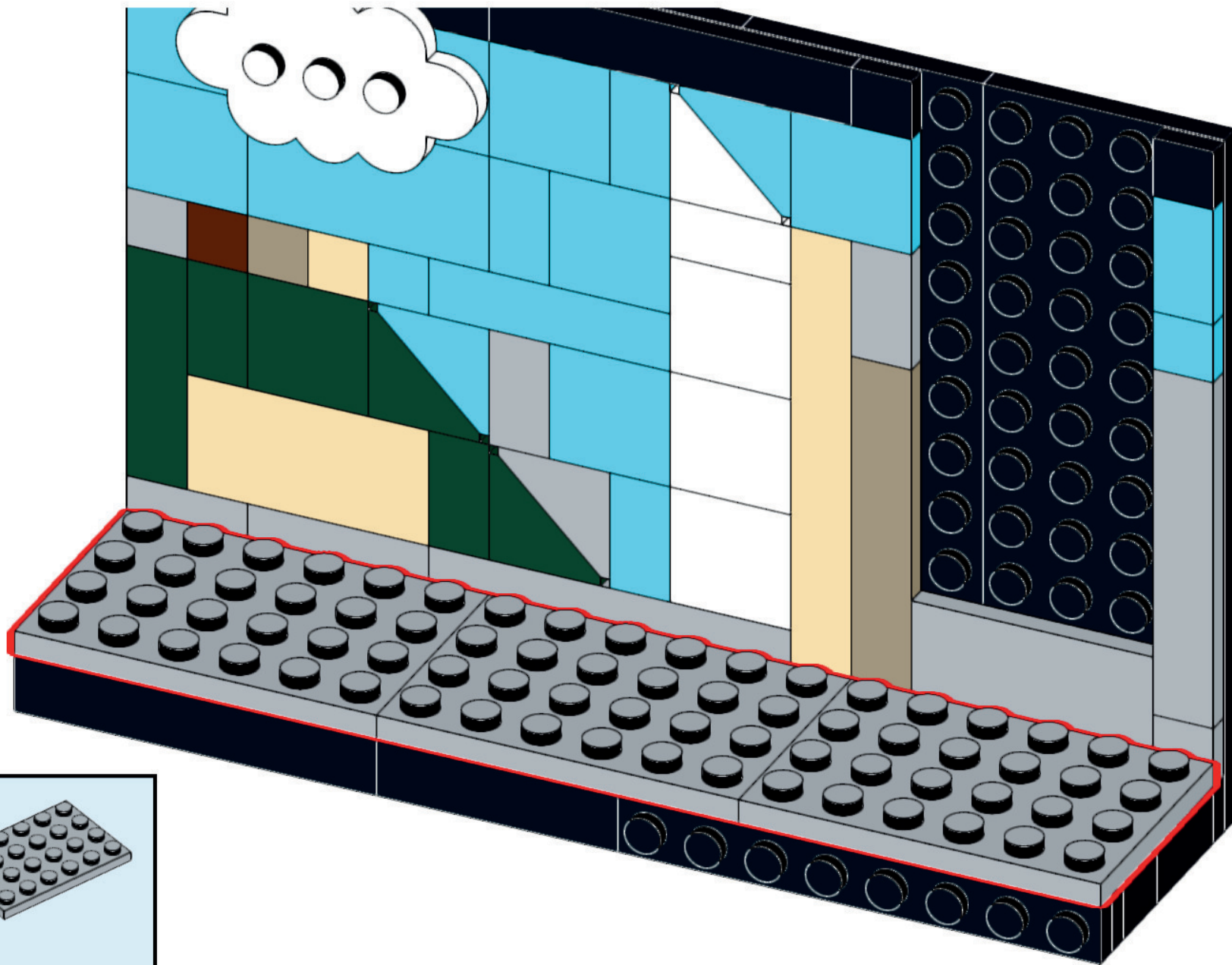

3x

11

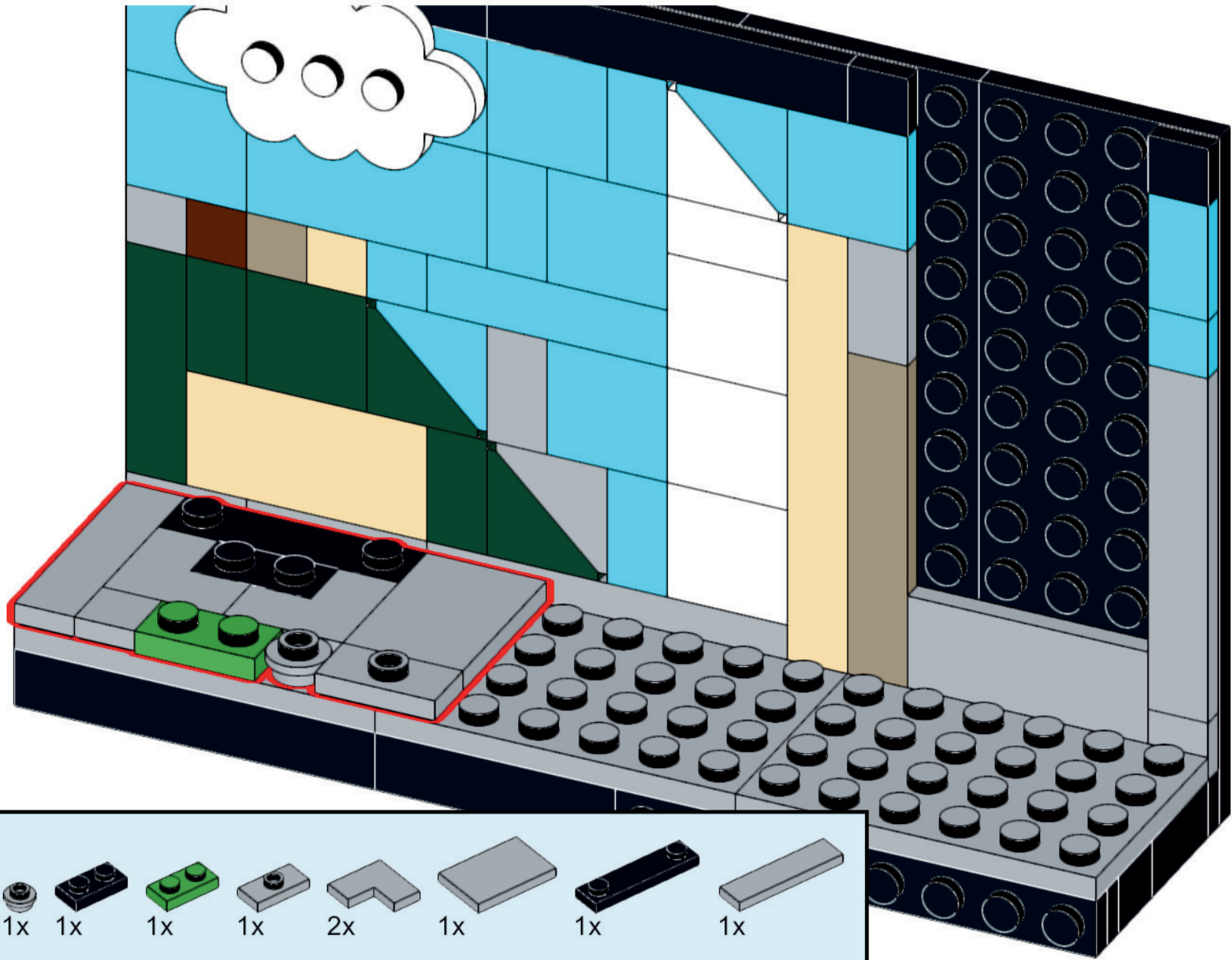

- 1x
- 1x
- 1x
- 1x
- 1x
- 2x
- 1x
- 1x
- 1x

12

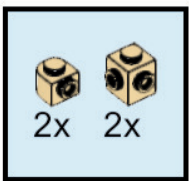
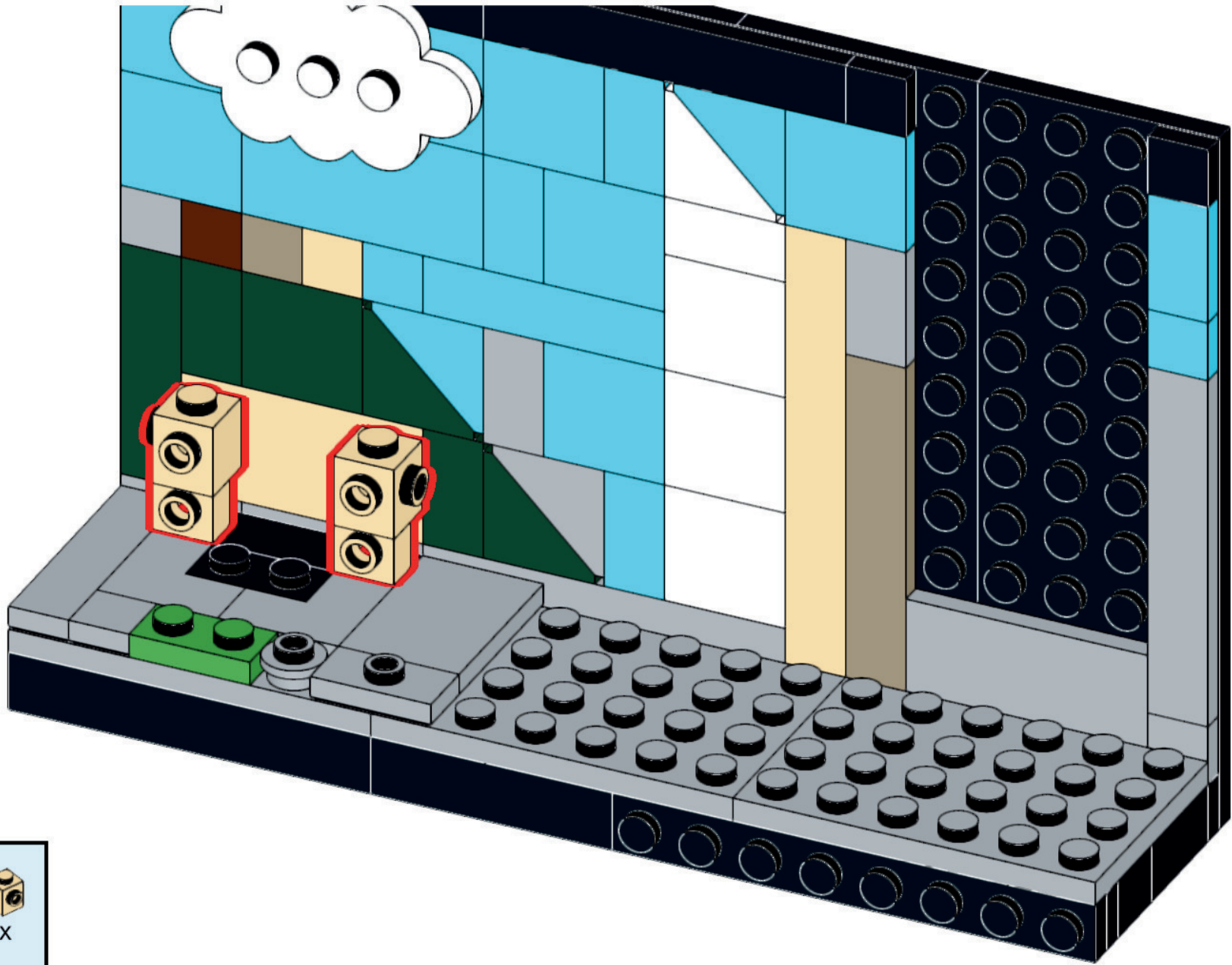

13

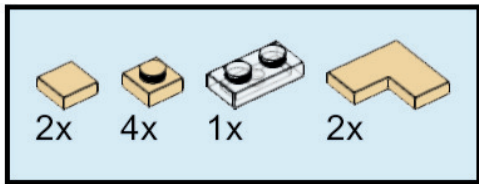
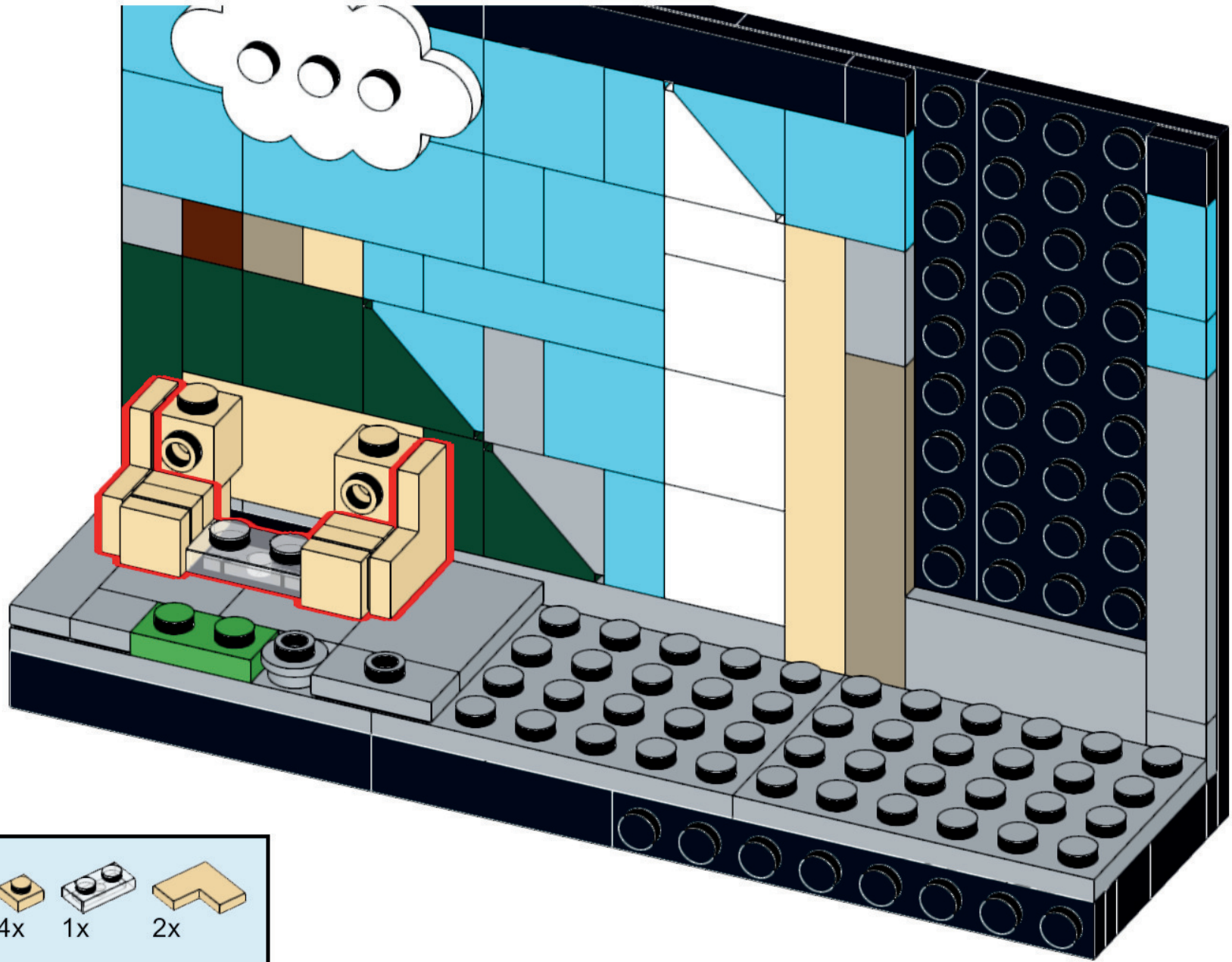

# 14

Veritcal windows do not connect to structure

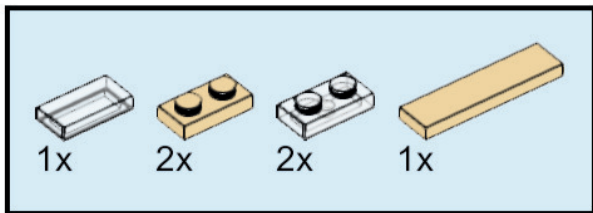
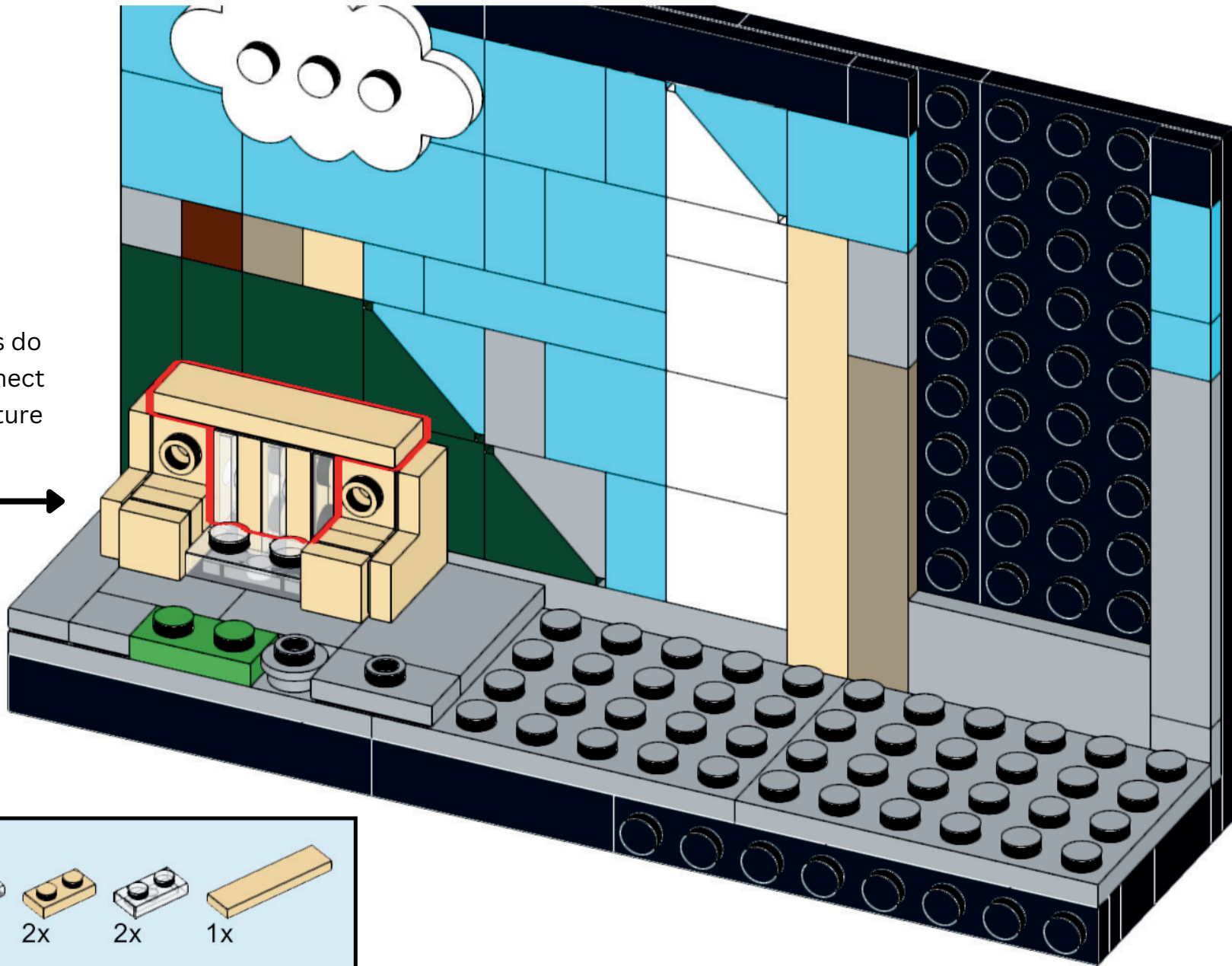
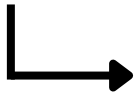

# 15

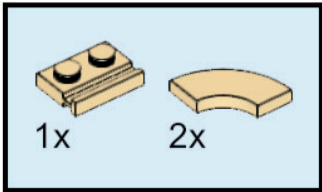
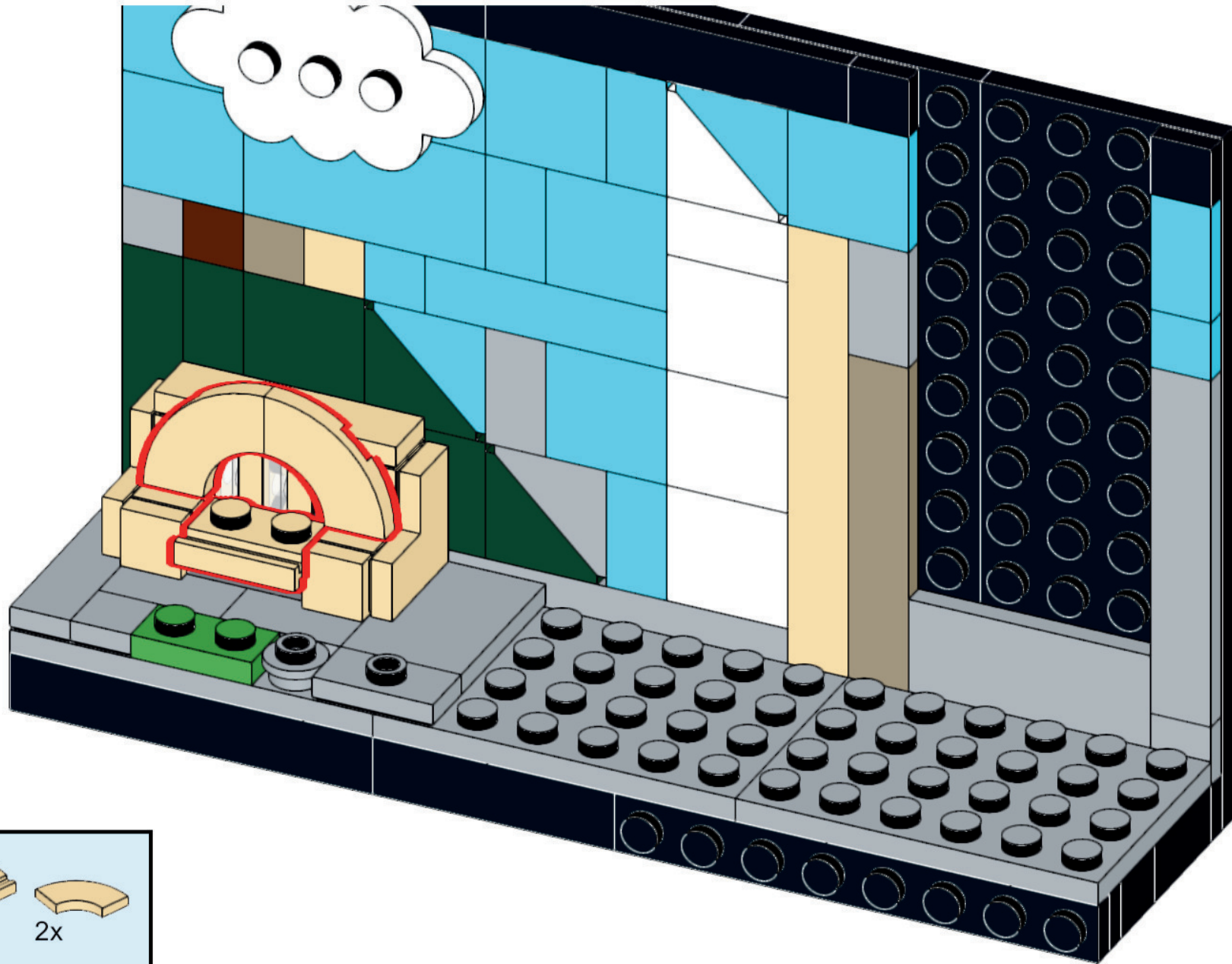

Union Terminal opened in 1933, and at its peak in the 1940s the station served over 200 trains per day. Presently it continues to serve train passengers and welcome thousands of museum visitors every year.

# 16

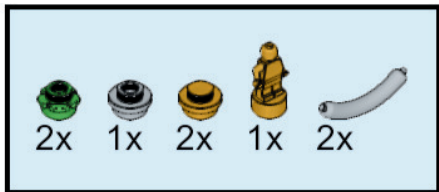
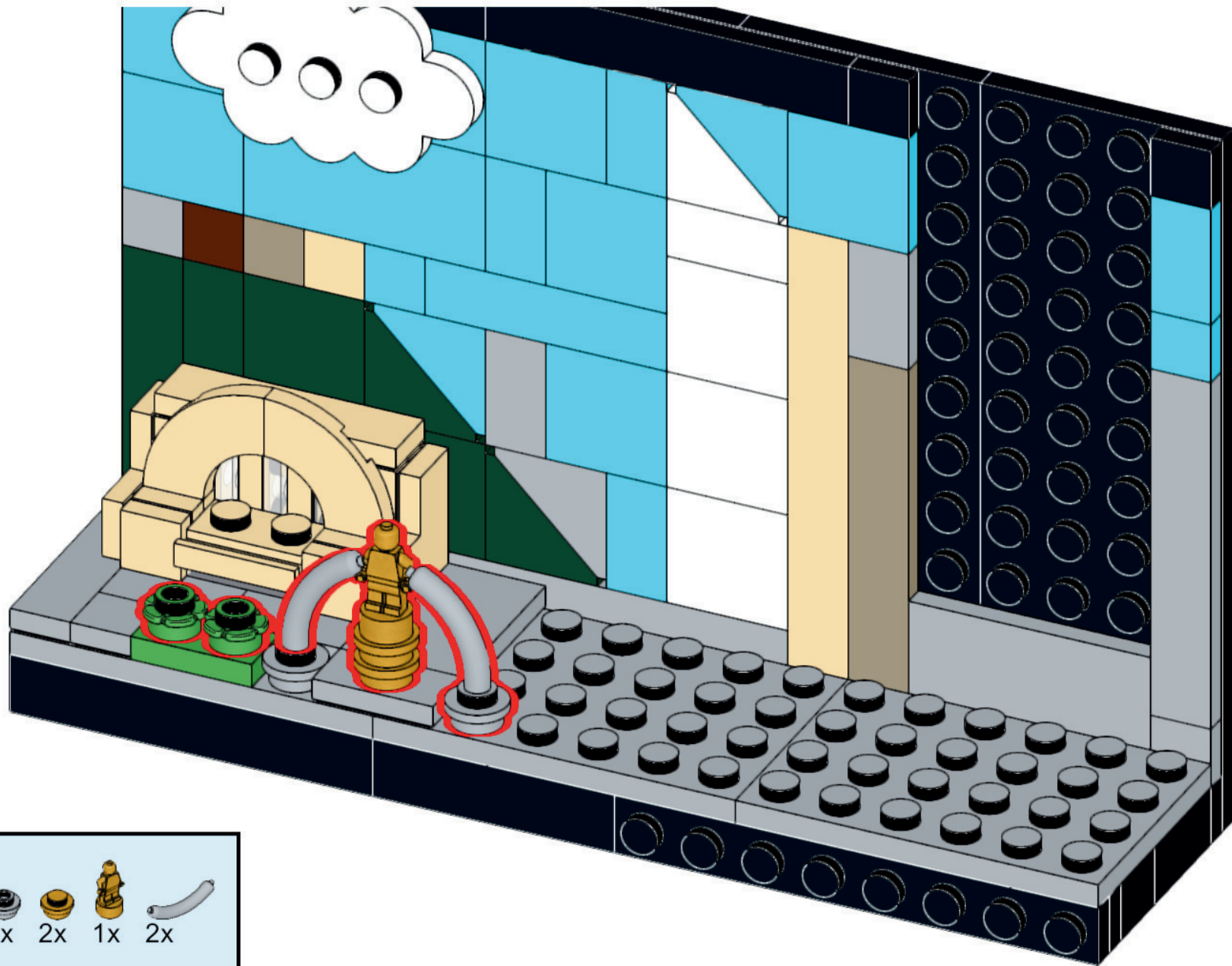

When the Tyler Davidson Fountain (located in Fountain Square) was dedicated in 1871, it wasn't just decorative—people, horses, and even dogs could drink from it, serving the bustling streets of 19<sup>th</sup> century Cincinnati.



18

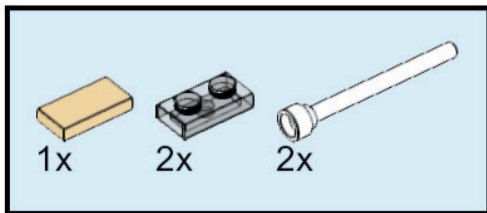
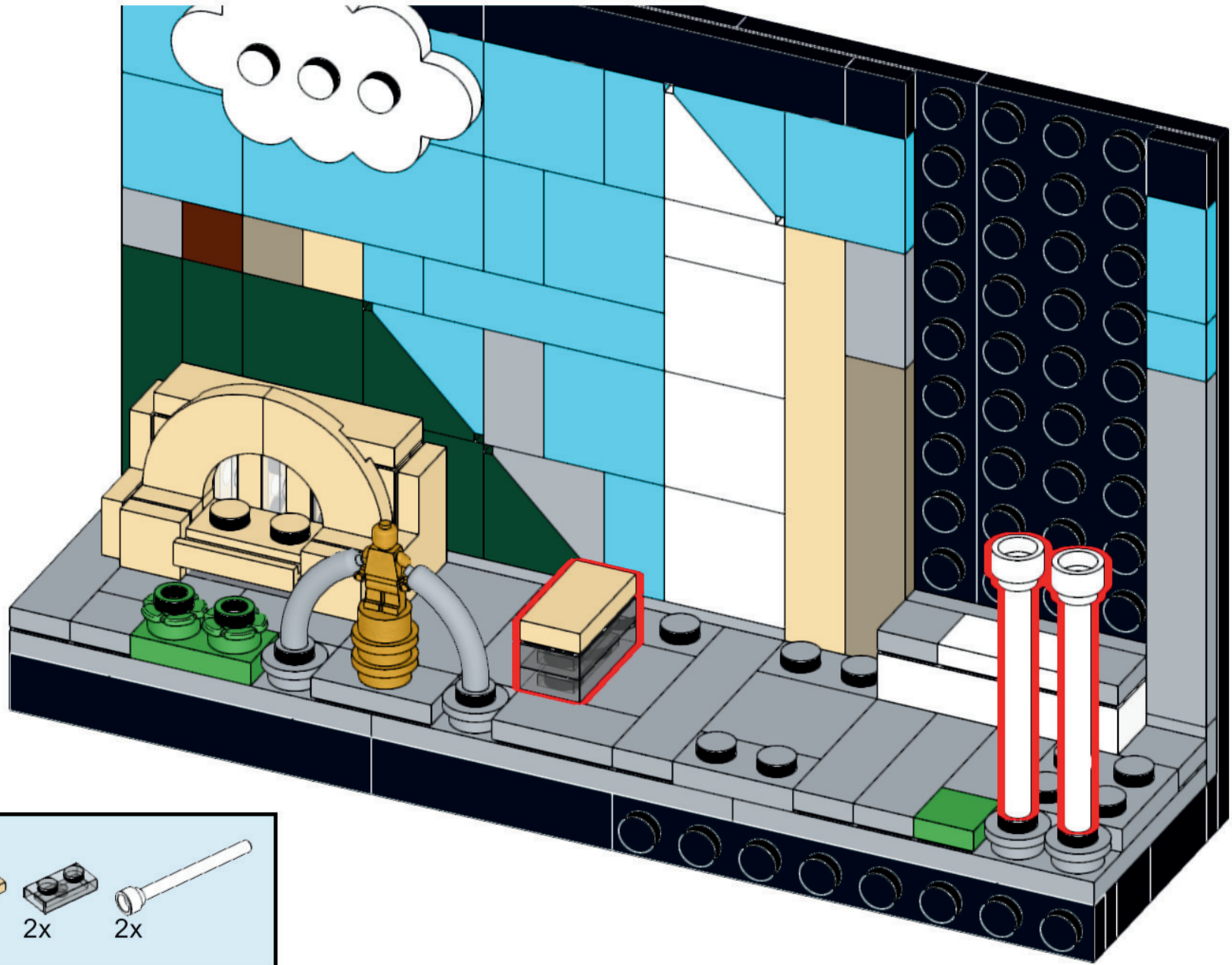

19

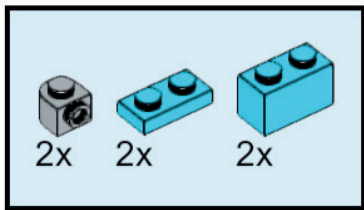
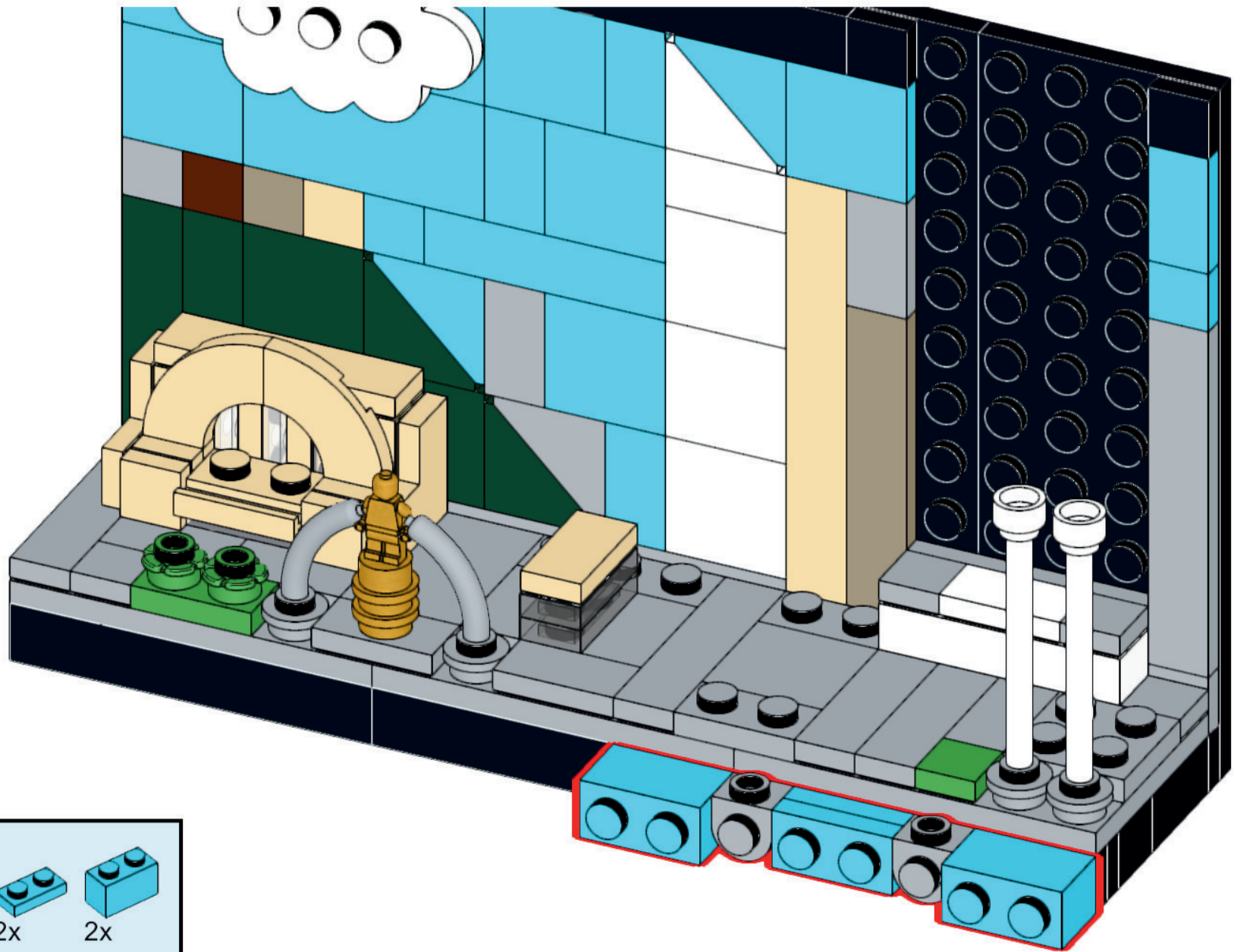

20

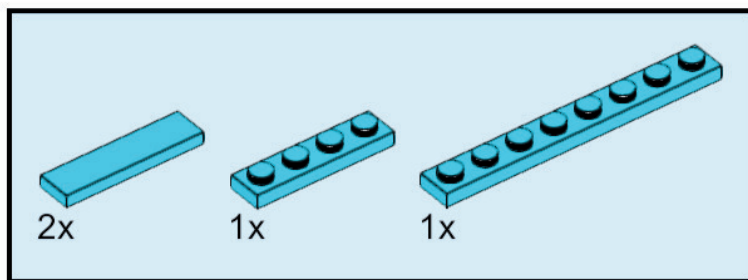
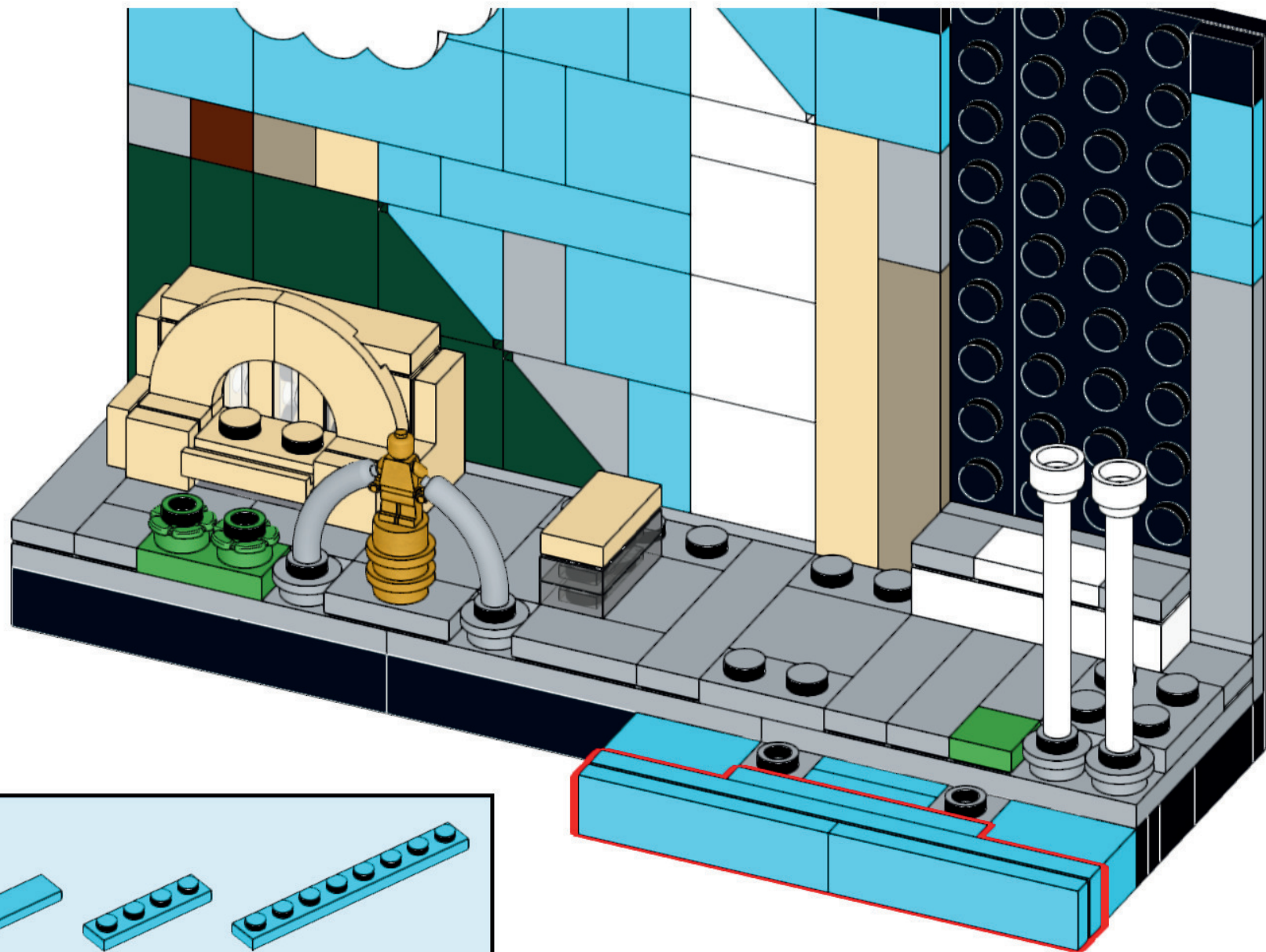

21

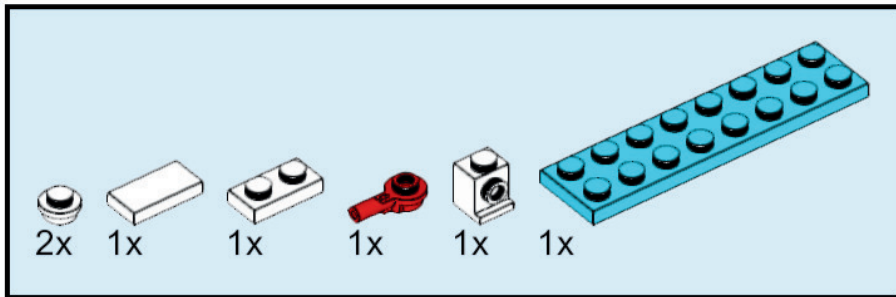
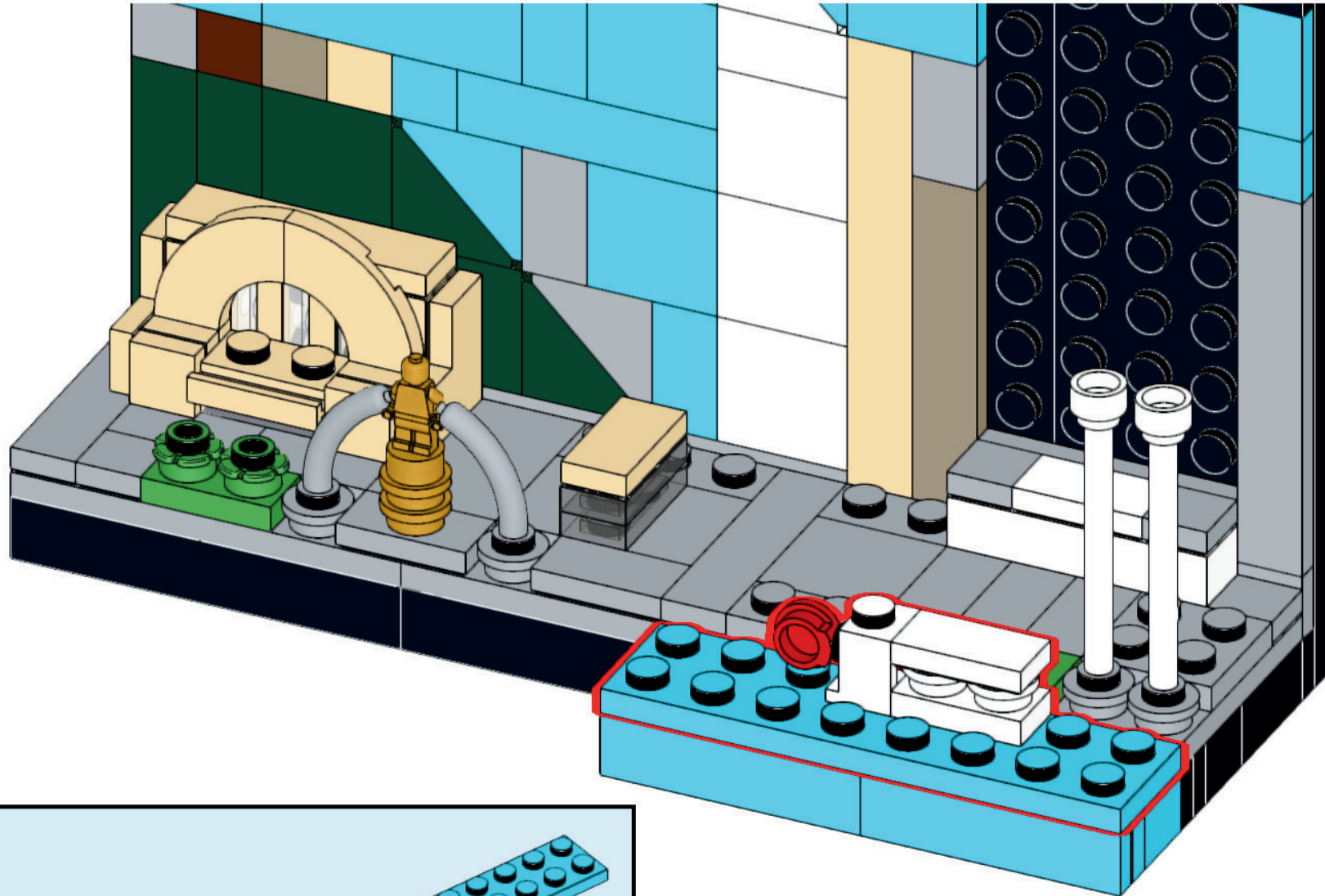

22

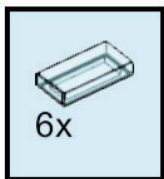
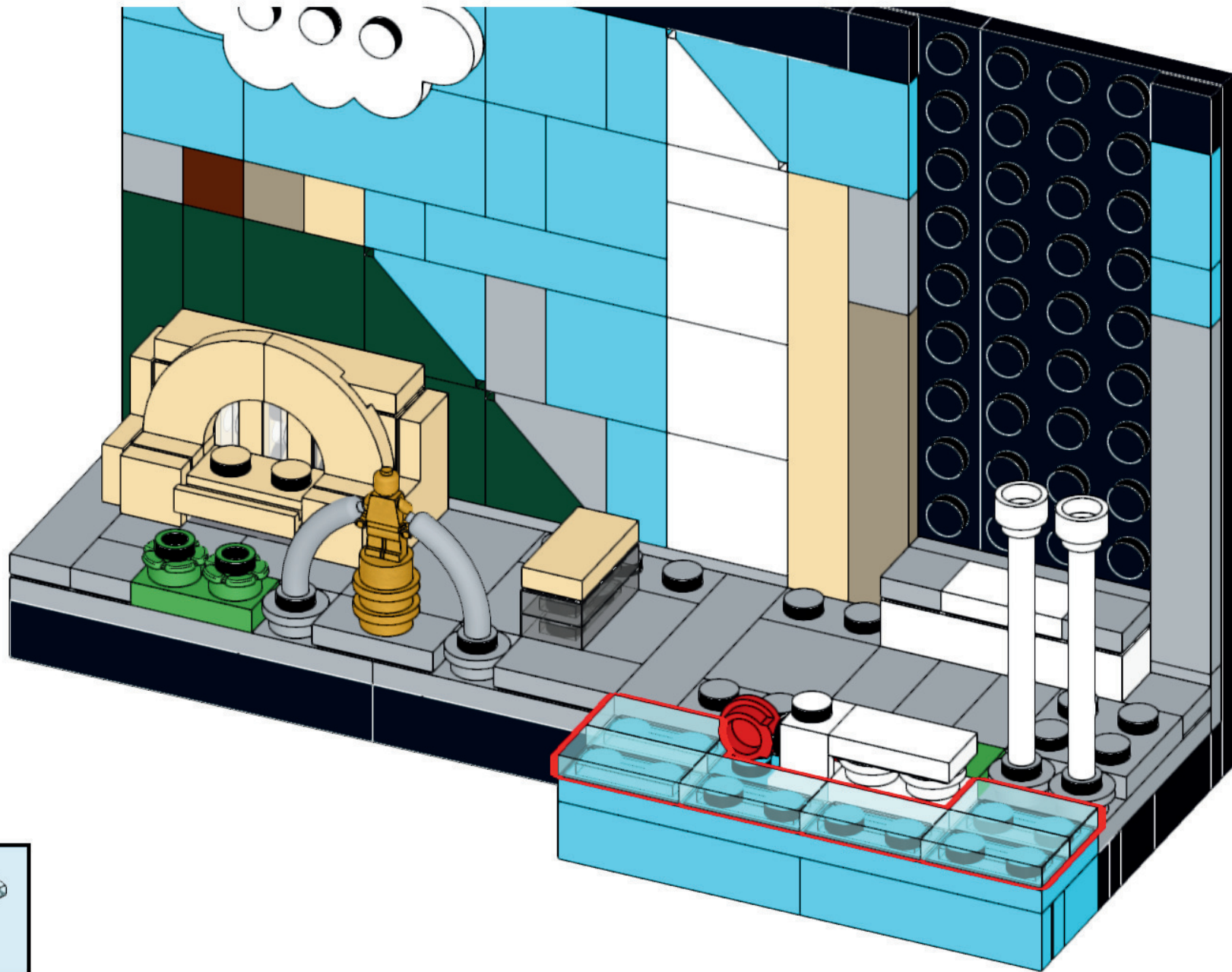

In the 19<sup>th</sup> century, Cincinnati was one of the busiest steamboat-building centers in the United States because of its location on the Ohio River.

# 23

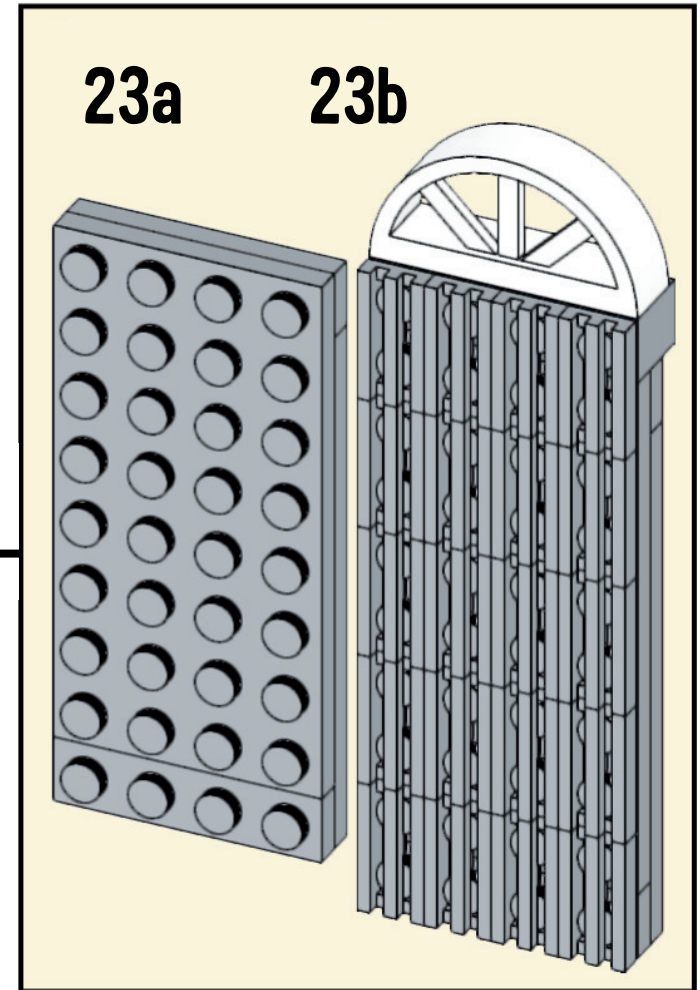
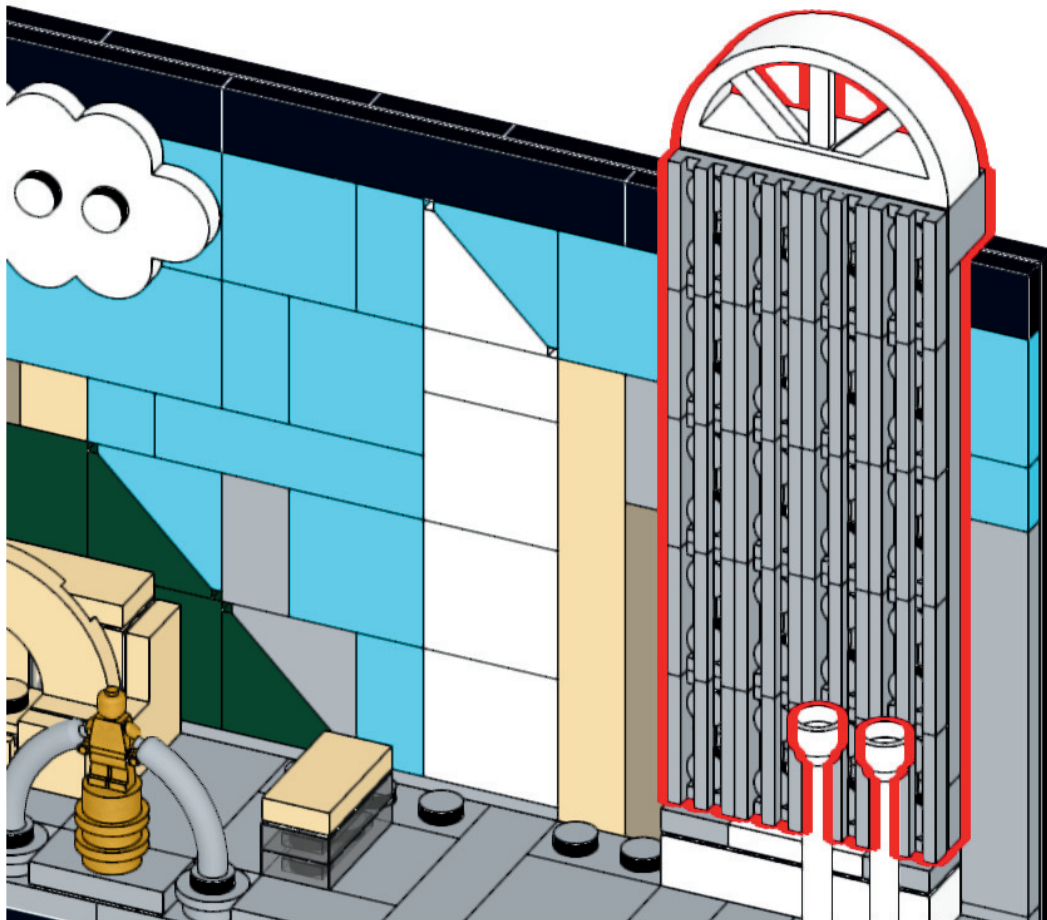
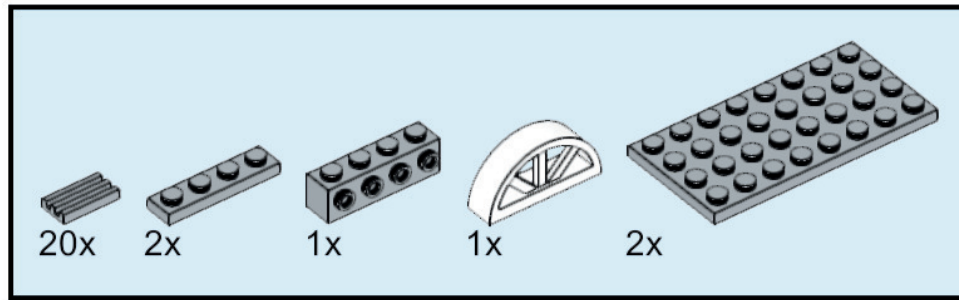

Completed in 2011, Great American Tower stands 665 feet tall, making it the tallest building in Cincinnati. The building's distinctive crown was designed to resemble a tiara, symbolizing the city's nickname, the "Queen City."

# 24

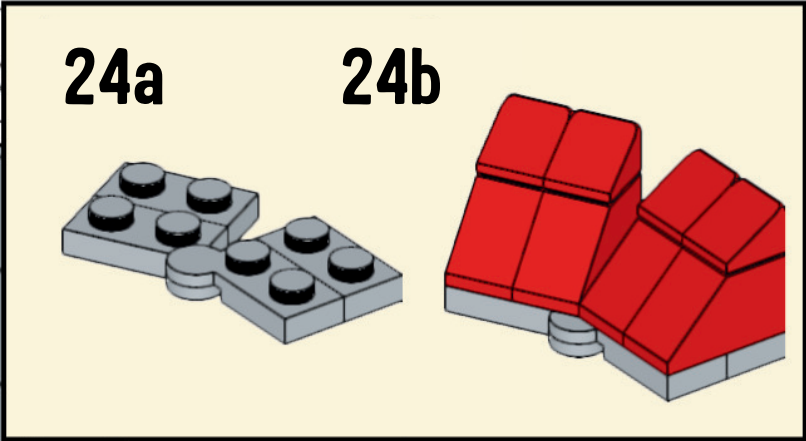
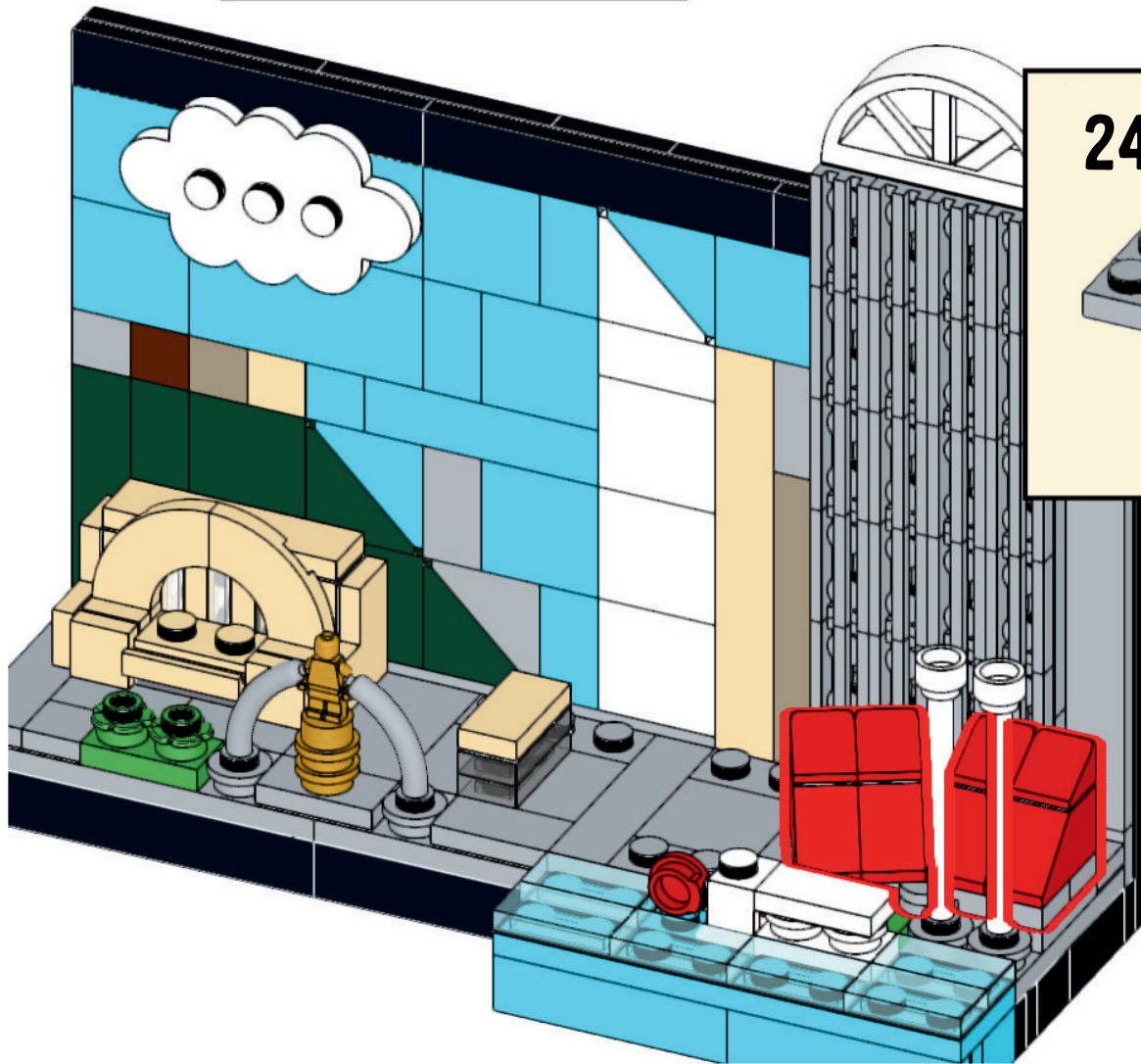
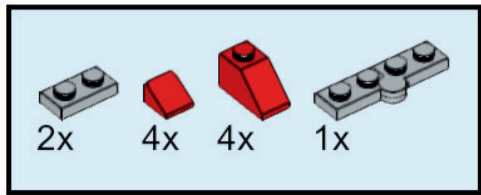

Great American Ball Park (2003) is home to the Cincinnati Reds baseball team. The stadium features riverboat themed decor that celebrate the city's steamboat heritage.

25

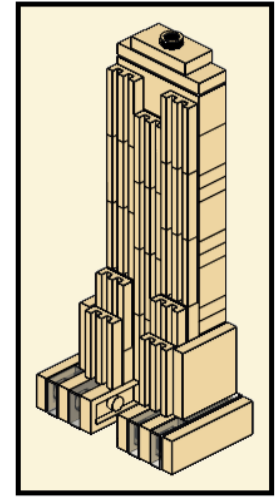
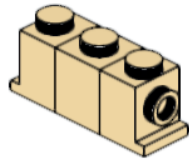
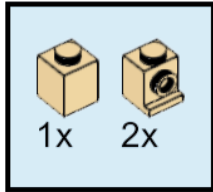

26

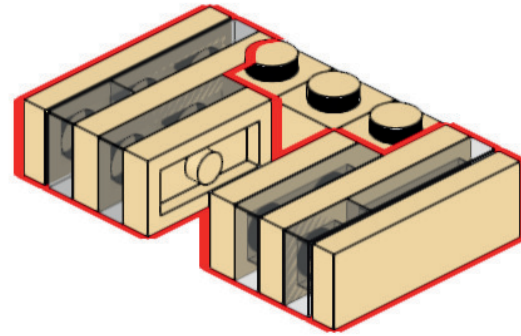
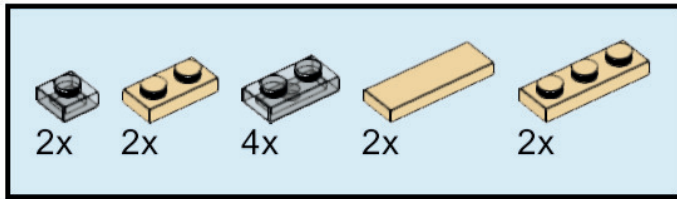

27

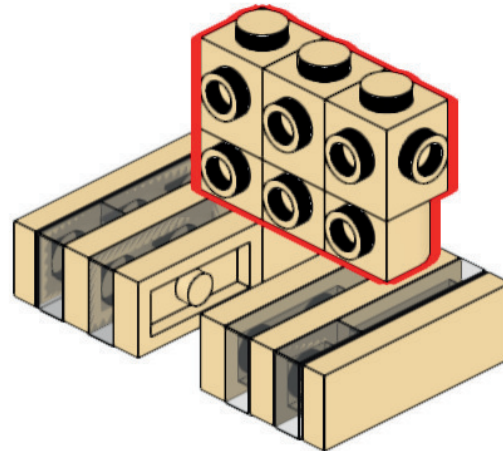
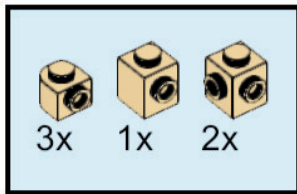

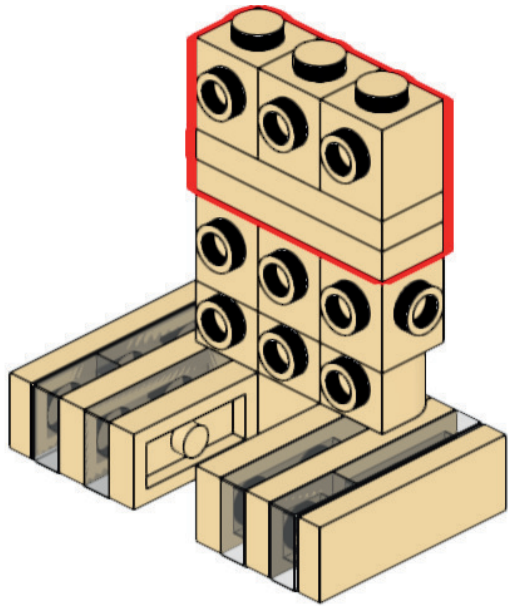

28

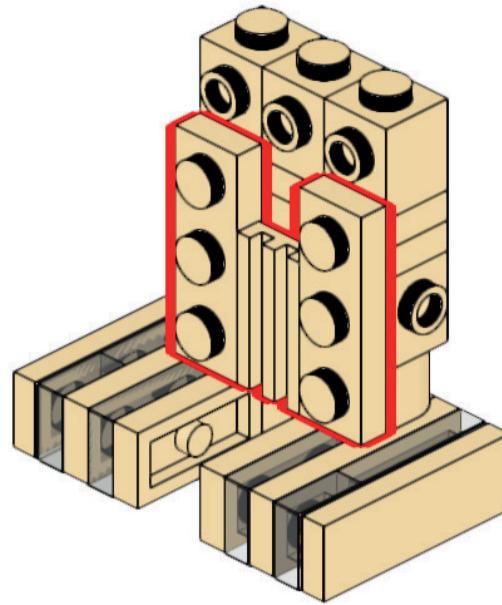
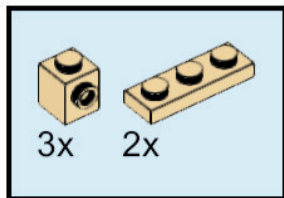

29

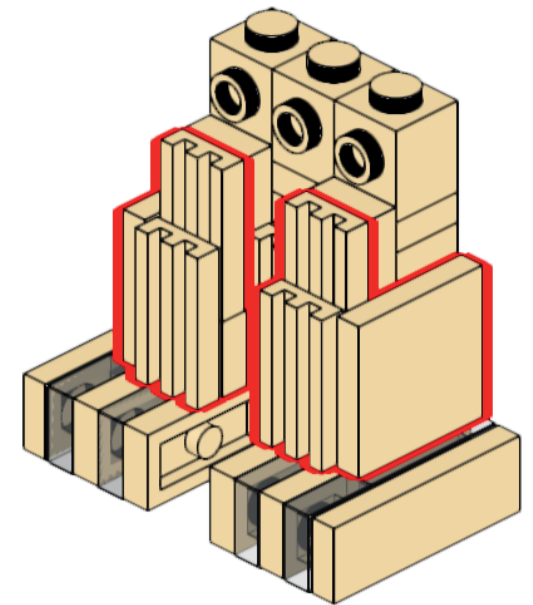
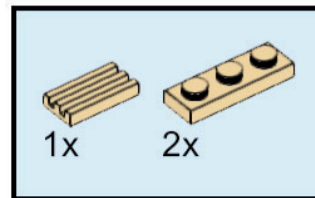

30

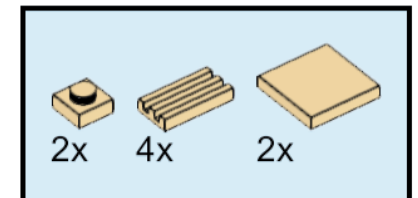

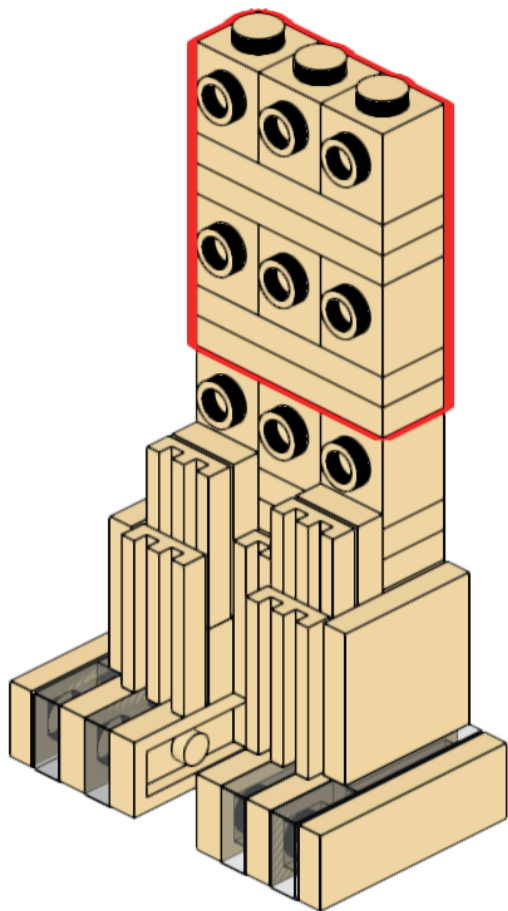

**31**

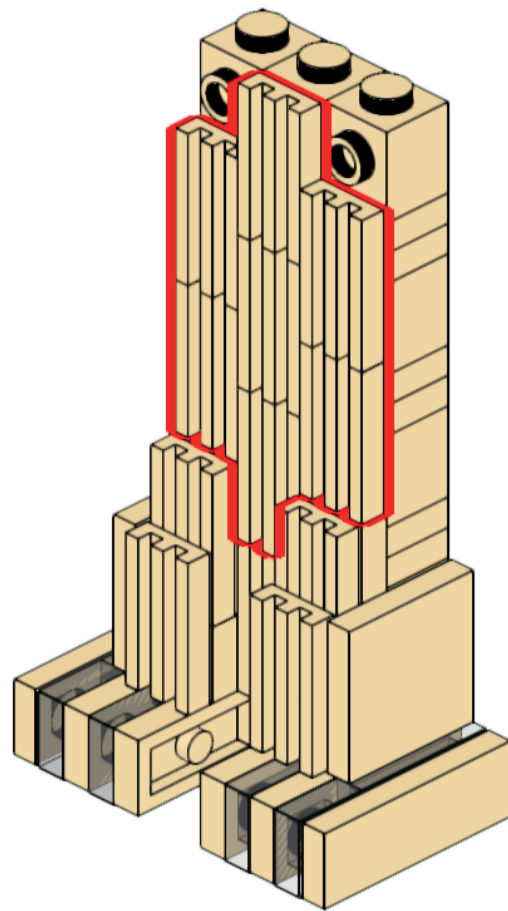
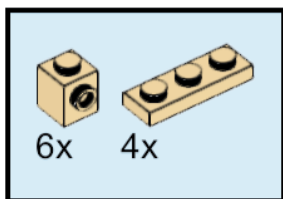

**32**

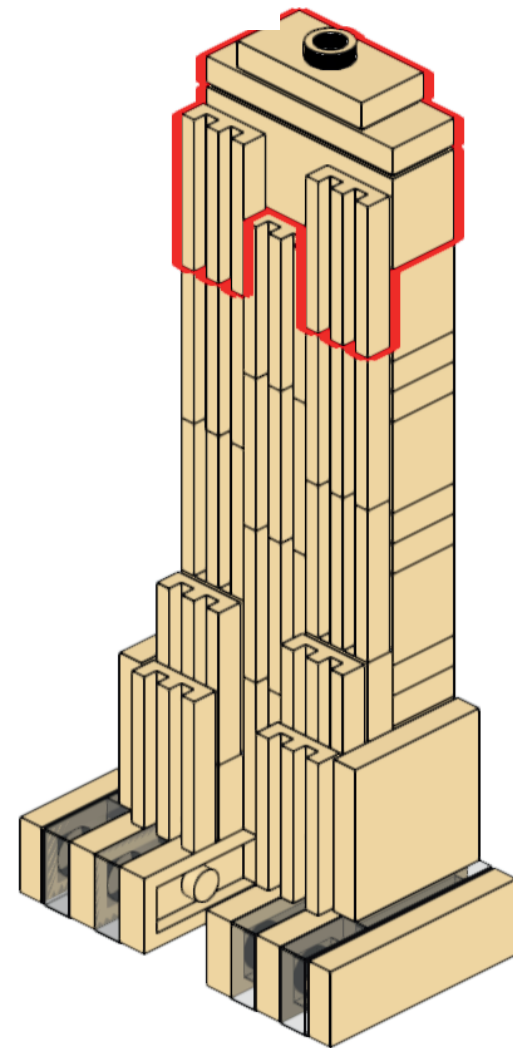
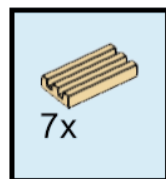

**33**

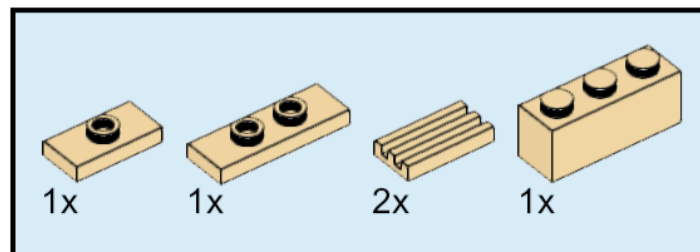

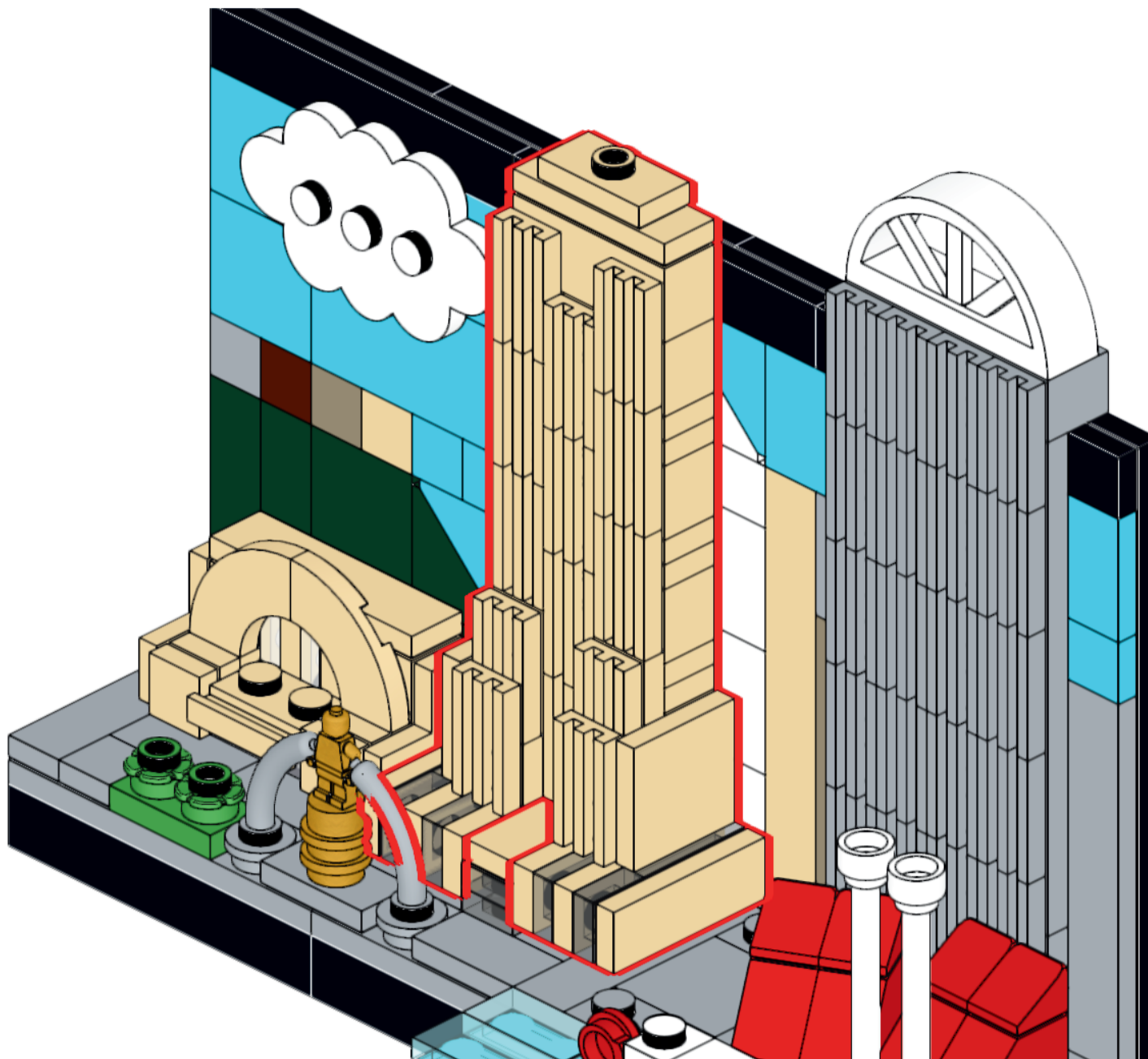

Carew Tower was completed in 1931, and remained Cincinnati's tallest skyscraper for 80 years. The tower and its hotel interiors are famous for Art Deco design with elements inspired by the 1925 Paris design exhibition.

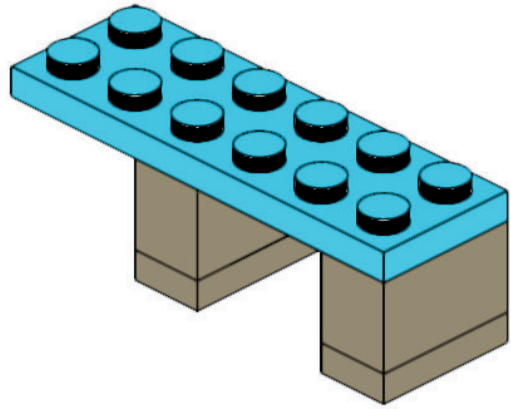

35

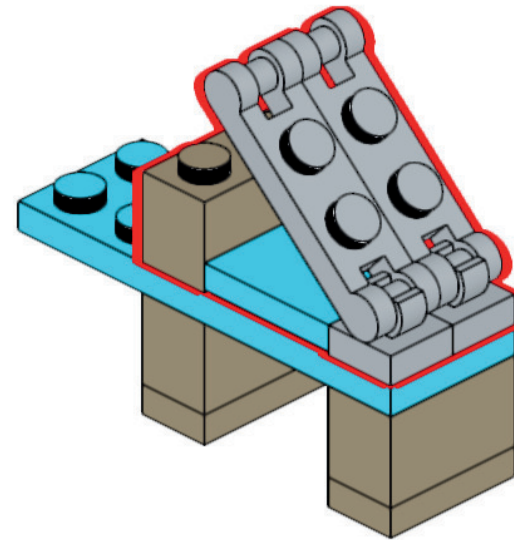
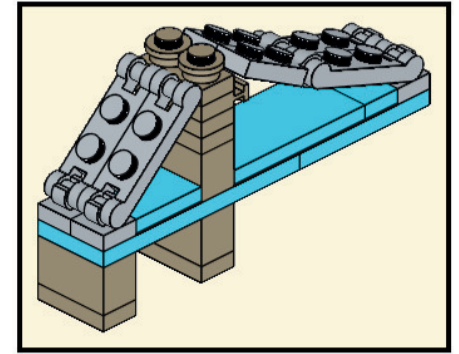
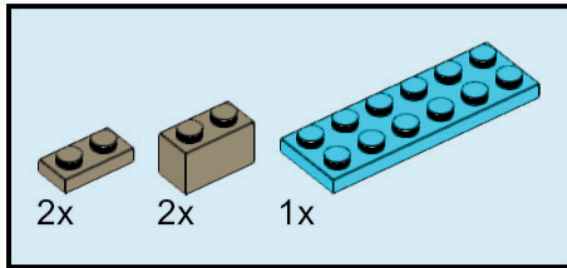

36

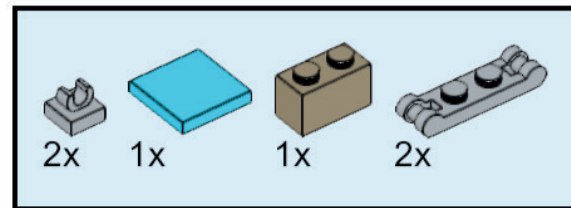

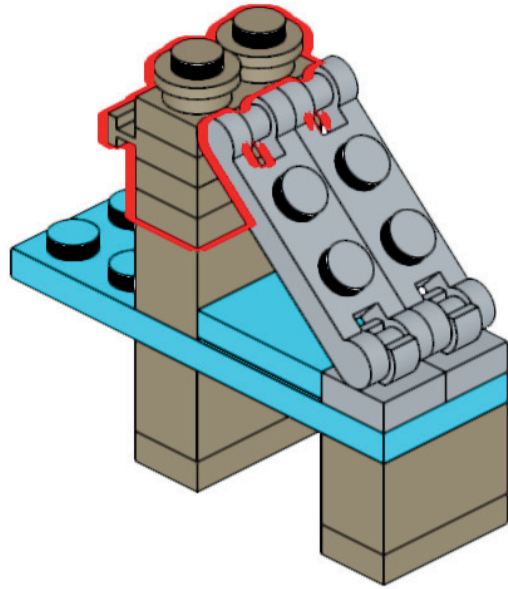

**37**

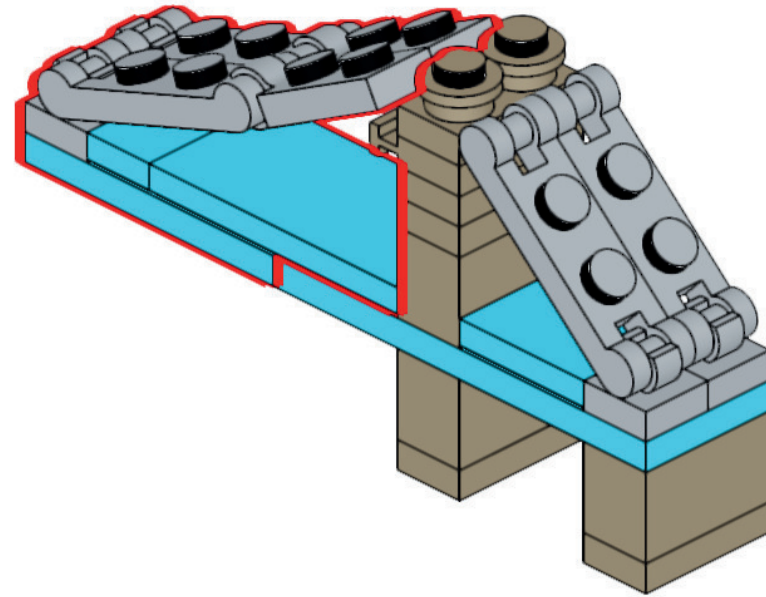
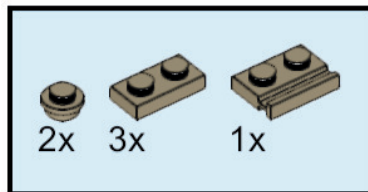

**38**

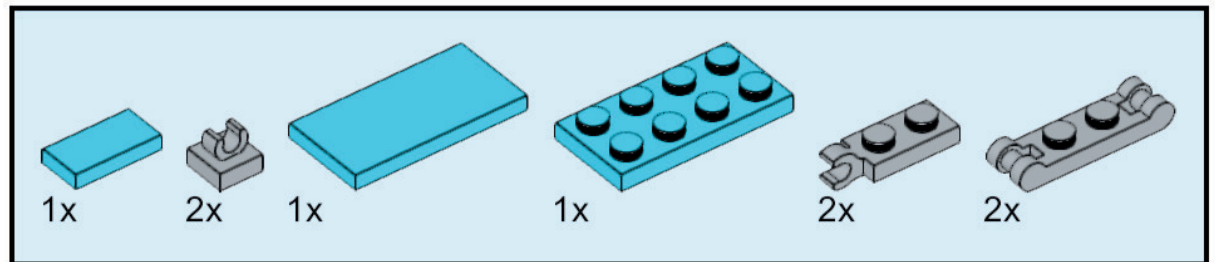

39

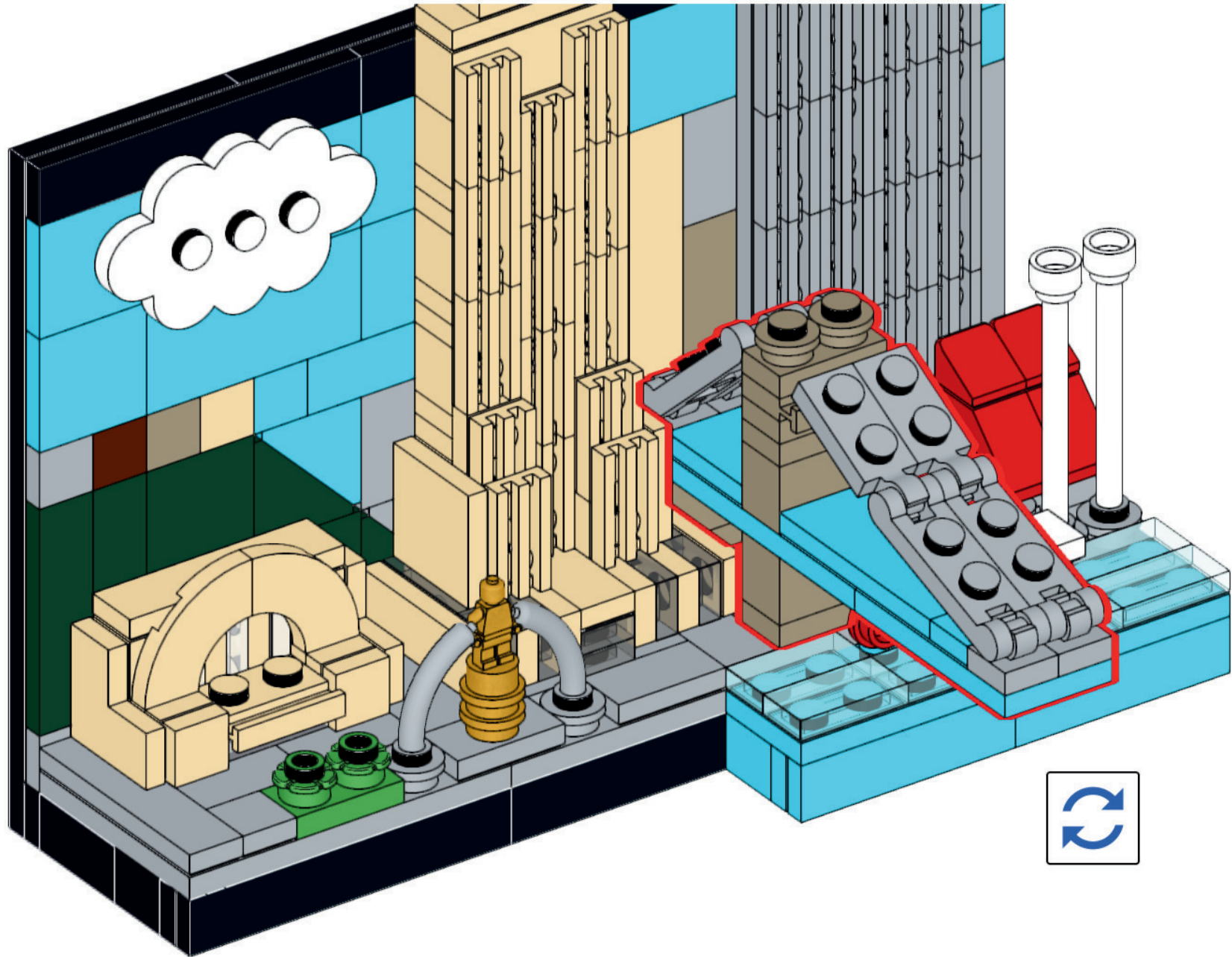

When the John A. Roebling Suspension Bridge opened in 1866, it had the longest suspension span in the world (1,057 feet). The bridge, spanning the Ohio River, was used as a blueprint for the Brooklyn Bridge in New York City.



2x  
307026



1x  
302326



4x  
300426



4x  
6275806



1x  
243126



1x  
6254045



3x  
663626



6x  
366626



1x  
346026



1x  
244526



4x  
302926



6x  
4211415



4x  
6168647



4x  
6308012



2x  
6448793



1x  
6066097



5x  
4211398



20x  
4211350



7x  
4211414



2x  
6436423



1x  
6217876



1x  
4211397



1x  
4211413



2x  
6065824



2x  
6319336



3x  
4558169



1x  
4211429



1x  
6171894



4x  
6093058



2x  
4211356



2x  
4211445

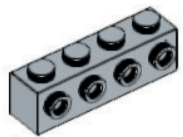

1x  
4211636

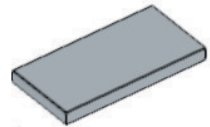

1x  
4560183

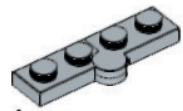

1x  
6416524

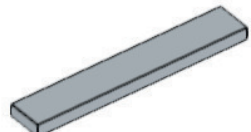

2x  
4211549



3x  
4211404

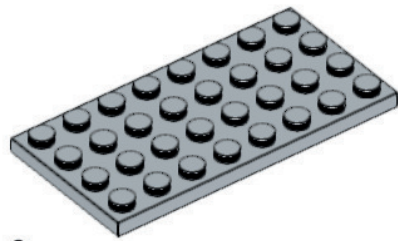

2x  
4211407



2x  
614101



1x  
407001



1x  
302301



3x  
306901



1x  
6217875

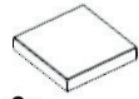

3x  
306801

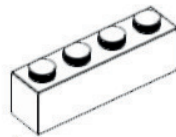

1x  
301001

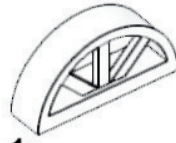

1x  
6173064



2x  
395701



1x  
6223667



4x  
4504379



1x  
6384112



4x  
4121934



1x  
4211288



1x  
6055172



2x  
6315781



5x  
4528604



1x  
4616711



3x  
4521914



10x  
4579260

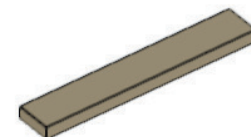

1x  
4507047



3x  
4125253



6x  
4159553



5x  
6454934



2x  
4118793



1x  
4113915



10x  
4579260



4x  
6175968



1x  
4114026



1x  
6092587



4x  
4113917



14x  
4124456



1x  
4160483



2x  
4185177



2x  
6226565

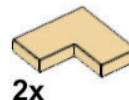

2x  
6173057



1x  
6211966



2x  
6131896



10x  
4121921

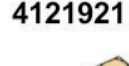

1x  
4162465



1x  
4550324

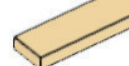

1x  
4550324



1x  
6122047

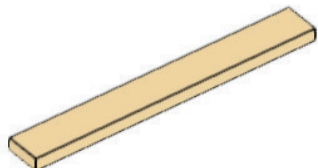

1x  
4544139

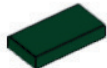

2x  
6326011



2x  
6390053

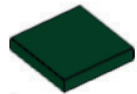

1x  
4528778



1x  
4543949



1x  
6172375



2x  
6206150



1x  
6343326



3x  
4655243



5x  
4649741



2x  
6097419



2x  
6347670



2x  
6092674

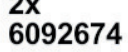

7x  
6060857



1x  
6465291



1x  
6070757

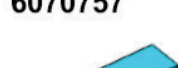

4x  
4624705



1x  
4655256



2x  
6097042



1x  
6146926



1x  
6074793

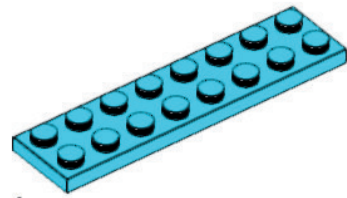

1x  
6253666



2x  
6513968



6x  
6514010



3x  
6514001



1x  
6514223

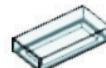

6x  
6514224



2x  
4523159



1x  
6335932